

BUSH HOG®

320 Series Rotary Cutters 325, 326, 327 Operator's Manual



BUSH HOG®
Performance You Can Count OnSM

ASSEMBLY ● OPERATION ● MAINTENANCE

CONGRATULATIONS!

You have invested in the best implement of its type on the market today.

The care you give your Bush Hog implement will greatly determine your satisfaction with its performance and its service life. We urge a careful study of this manual to provide you with a thorough understanding of your new implement before operating, as well as suggestions for operation and maintenance.

If your manual should become lost or destroyed, Bush Hog will be glad to provide you with a new copy. Order from Bush Hog, P. O. Box 1039, Selma, Alabama 36702-1039. Most of our manuals can also be downloaded from our website at www.bushhog.com.

As an authorized Bush Hog dealer, we stock genuine Bush Hog parts which are manufactured with the same precision and skill as our original equipment. Our trained service personnel are well informed on methods required to service Bush Hog equipment, and are ready and able to help you.

Should you require additional information or assistance, please contact us.

YOUR AUTHORIZED
BUSH HOG DEALER

BECAUSE BUSH HOG MAINTAINS AN ONGOING PROGRAM OF PRODUCT IMPROVEMENT, WE RESERVE THE RIGHT TO MAKE IMPROVEMENTS IN DESIGN OR CHANGES IN SPECIFICATIONS WITHOUT INCURRING ANY OBLIGATION TO INSTALL THEM ON UNITS PREVIOUSLY SOLD.

BECAUSE OF THE POSSIBILITY THAT SOME PHOTOGRAPHS IN THIS MANUAL WERE TAKEN OF PROTOTYPE MODELS, PRODUCTION MODELS MAY VARY IN SOME DETAIL. IN ADDITION, SOME PHOTOGRAPHS MAY SHOW SHIELDS REMOVED FOR PURPOSES OF CLARITY. **NEVER OPERATE** THIS IMPLEMENT WITHOUT ALL SHIELDS IN PLACE.

325, 326, 327 SERIES ROTARY CUTTERS

TABLE OF CONTENTS

| SECTION/PARA | PAGE | SECTION/PARA | PAGE |
|---------------------------------------|------|---|------|
| Warranty | 2 | 4-2 Lubrication | 10 |
| Dealer Preparation Check List | 3 | 4-3 Blade Holder Assembly Removal and Installation | 11 |
| Safety Precautions | 4 | 4-4 Blade Replacement | 11 |
| Federal Laws and Regulations | 5 | 4-5 Slip Clutch Operational Check | 11 |
| I. INTRODUCTION & DESCRIPTION | 6 | 4-6 Slip Clutch Adjustment | 12 |
| 1-1 Introduction | 6 | 4-7 Gearbox Maintenance | 12 |
| 1-2 Description | 6 | 4-8 Troubleshooting | 13 |
| II. PREPARATION FOR USE | 7 | V. ASSEMBLY | 14 |
| 2-1 Attaching To Tractor | 7 | 5-1 Models 325 & 326 | 15 |
| III. OPERATING INSTRUCTIONS | 9 | 5-2 Model 327 Lift Type | 16 |
| 3-1 General Safety | 9 | 5-3 Model 327 Pull Type | 18 |
| 3-2 Adjusting for Work | 9 | 5-4 Rear Band Installation | 20 |
| 3-2.1 Cutting Height Adjustment | 9 | 5-5 Front Chain Installation | 20 |
| 3-3 Operation | 9 | 5-6 Rear Chain Installation | 20 |
| 3-4 Transporting | 10 | Safety Decals | 16 |
| IV. MAINTENANCE | 10 | Torque Specifications | 17 |
| 4-1 Maintenance Check List | 10 | | |

RETAIL CUSTOMER'S RESPONSIBILITY UNDER THE BUSH HOG WARRANTY

It is the Retail Customer and/or Operator's responsibility to read the Operator's Manual, to operate, lubricate, maintain and store the product in accordance with all instructions and safety procedures. Failure of the operator to read the Operator's Manual is a misuse of this equipment.

It is the Retail Customer and/or Operator's responsibility to inspect the product and to have any part(s) repaired or replaced when continued operation would cause damage or excessive wear to other parts or cause a safety hazard.

It is the Retail Customer's responsibility to deliver the product to the authorized Bush Hog Dealer, from whom he purchased it, for service or replacement of defective parts which are covered by warranty. Repairs to be submitted for warranty consideration must be made within thirty (30) days of failure.

It is the Retail Customer's responsibility for any cost incurred by the Dealer for traveling to or hauling of the product for the purpose of performing a warranty obligation or inspection.



BUSH HOG®
Performance You Can Count OnSM

LIMITED WARRANTY



Bush Hog warrants to the original purchaser of any new Bush Hog equipment, purchased from an authorized Bush Hog dealer, that the equipment be free from defects in material and workmanship for a period of one (1) year for non-commercial, state, and municipalities' use and ninety (90) days for commercial use from date of retail sale. The 320 series gearboxes are covered by a five (5) year limited warranty. The obligation of Bush Hog to the purchaser under this warranty is limited to the repair or replacement of defective parts.

Replacement or repair parts installed in the equipment covered by this limited warranty are warranted for ninety (90) days from the date of purchase of such part or to the expiration of the applicable new equipment warranty period, whichever occurs later. Warranted parts shall be provided at no cost to the user at an authorized Bush Hog dealer during regular working hours. Bush Hog reserves the right to inspect any equipment or parts which are claimed to have been defective in material or workmanship.

DISCLAIMER OF IMPLIED WARRANTIES & CONSEQUENTIAL DAMAGES

Bush Hog's obligation under this limited warranty, to the extent allowed by law, is in lieu of all warranties, implied or expressed, **INCLUDING IMPLIED WARRANTIES OF MERCHANTABILITY AND FITNESS FOR A PARTICULAR PURPOSE** and any liability for incidental and consequential damages with respect to the sale or use of the items warranted. Such incidental and consequential damages shall include but not be limited to: transportation charges other than normal freight charges; cost of installation other than cost approved by Bush Hog; duty; taxes; charges for normal service or adjustment; loss of crops or any other loss of income; rental of substitute equipment, expenses due to loss, damage, detention or delay in the delivery of equipment or parts resulting from acts beyond the control of Bush Hog.

THIS LIMITED WARRANTY SHALL NOT APPLY:

1. To vendor items which carry their own warranties, such as engines, tires, and tubes.
2. If the unit has been subjected to misapplication, abuse, misuse, negligence, fire or other accident.
3. If parts not made or supplied by Bush Hog have been used in connection with the unit, if, in the sole judgement of Bush Hog such use affects its performance, stability or reliability.
4. If the unit has been altered or repaired outside of an authorized Bush Hog dealership in a manner which, in the sole judgement of Bush Hog, affects its performance, stability or reliability.
5. To normal maintenance service and normal replacement items such as gearbox lubricant, hydraulic fluid, worn blades, or to normal deterioration of such things as belts and exterior finish due to use or exposure.
6. To expendable or wear items such as teeth, chains, sprockets, belts, springs and any other items that in the company's sole judgement is a wear item.

NO EMPLOYEE OR REPRESENTATIVE OF BUSH HOG IS AUTHORIZED TO CHANGE THIS LIMITED WARRANTY IN ANY WAY OR GRANT ANY OTHER WARRANTY UNLESS SUCH CHANGE IS MADE IN WRITING AND SIGNED BY BUSH HOG'S SERVICE MANAGER, POST OFFICE BOX 1039, SELMA, ALABAMA 36702-1039.



Record the model number, serial number and date purchased. This information will be helpful to your dealer if parts or service are required.

MODEL NUMBER _____

MAKE CERTAIN THE WARRANTY REGISTRATION CARD HAS BEEN FILED WITH BUSH HOG/
SELMA, ALABAMA

SERIAL NUMBER _____

DATE OF RETAIL SALE _____

DEALER PREPARATION CHECK LIST

325, 326, 327 SERIES ROTARY CUTTERS

BEFORE DELIVERING MACHINE — The following check list should be completed.
Use the Operator's Manual as a guide.

- 1. Assembly completed.
- 2. Gearbox filled with oil.
- 3. All fittings lubricated.
- 4. All shields in place and in good condition.
- 5. All fasteners torqued to specifications given in Torque Chart.
- 6. Slip clutches have been checked for proper operation.
- 7. All decals in place and readable. (See decal page.)
- 8. Overall condition good (i.e. paint, welds)
- 9. Operators manual has been delivered to owner and he has been instructed on the safe and proper use of the cutter.
- 10. Purchaser or dealer elects to delete deflectors. (front chains)

Explanation: _____

WARNING

Deflector kit or chain shielding is standard equipment. Must be used for all non-agricultural uses or in areas where the possibility of thrown objects could be hazardous to persons or property. Use 5/16" double row highway chains for all roadside mowing operations.

Dealer's
Signature _____

Purchaser's
Signature _____

THIS CHECKLIST TO REMAIN IN OWNER'S MANUAL

It is the responsibility of the dealer to complete the procedures listed above before delivery of this implement to the customer.

IMPORTANT SAFETY PRECAUTIONS

This symbol is used to call attention to safety precautions that should be followed by the operator to avoid accidents. When you see this symbol, carefully read the message that follows and heed its advice. Failure to comply with safety precautions could result in serious bodily injury.



In addition to the design and configuration of equipment, hazard control and accident prevention are dependent upon the awareness, concern, prudence and proper training of personnel in the operation, transport, maintenance and storage of equipment. Lack of attention to safety can result in accident, personal injury, reduction of efficiency and worst of all—loss of life. Watch for safety hazards and correct deficiencies promptly. Use the following safety precautions as a general guide to safe operations when using this machine. Additional safety precautions are used throughout this manual for specific operating and maintenance procedures. Read this manual and review the safety precautions often until you know the limitations.

1. Read the Operator's Manual. Failure to read the Operator's Manual is considered a misuse of this equipment.
2. Become familiar with all the machine's controls and all the caution, warning and danger decals affixed to the machine before attempting to start or operate.
3. Before starting or operating the machine, make a walk around inspection and check for obvious defects such as loose mounting bolts and damaged components. Correct any deficiency before starting.
4. Do not allow children to operate the cutter. Do not allow adults to operate it without proper instruction.
5. Do not carry passengers.
6. Keep the area of operation clear of all persons, particularly small children and pets. The operator should cease mowing whenever anyone comes within the operating area.
7. Clear the work area of objects which might be picked up and thrown.
8. Use a piece of cardboard or wood rather than hands to search for hydraulic leaks. Escaping hydraulic oil under pressure can penetrate skin. If fluid is injected into the skin, it must be surgically removed within a few hours by a doctor familiar with this form of injury or gangrene may result.
9. Do not operate without all guards and shields in place and in good condition.
10. Lower implement to ground, stop tractor engine, apply parking brake, and allow blades to completely stop before leaving the tractor.
11. Keep hands and feet away from blades.
12. Use 5/16" double row highway chains for all roadside mowing operations.
13. Do not operate the cutter in the vicinity of other persons without enclosed sides, permanent bands, highway chains or other factory approved discharge shields in place and in good working order.
14. Wear personal protective equipment such as, but not limited to, protection for eyes, ears, feet, hands and head when operating or repairing the equipment. Do not wear loose clothing or jewelry that may catch on equipment moving parts.
15. When performing adjustments or maintenance on the cutter, first lower it to the ground or block it securely at a workable height.
16. Never stand between tractor and cutter while tractor is being backed to the cutter hitch.
17. Reduce speed when transporting cutter to avoid bouncing and momentary loss of steering.
18. Use tractor flashing warning lights, day or night, when transporting cutter on road or highways unless prohibited by law.
19. In the event that someone other than yourself will operate this equipment we firmly suggest that all SAFETY references be discussed prior to operation.
20. Use ROPS (Rollover Protective Structures) and seat belt equipped tractors for mowing operations.

IMPORTANT FEDERAL LAWS AND REGULATIONS* CONCERNING EMPLOYERS, EMPLOYEES AND OPERATIONS.

*(This section is intended to explain in broad terms the concept and effect of the following federal laws and regulations. It is not intended as a legal interpretation of the laws and should not be considered as such).

U.S. Public Law 91-596 (The Williams-Steiger Occupational and Health Act of 1970) OSHA

This Act Seeks:

“...to assure so far as possible every working man and woman in the nation safe and healthful working conditions and to preserve our human resources...”

DUTIES

Sec. 5 (a) Each employer—

- (1) shall furnish to each of his employees employment and a place of employment which are free from recognized hazards that are causing or are likely to cause death or serious physical harm to his employees;
- (2) shall comply with occupational safety and health standards promulgated under this Act.
 - (b) Each employee shall comply with occupational safety and health standards and all rules, regulations and orders issued pursuant to this Act which are applicable to his own actions and conduct.

OSHA Regulations

Current OSHA regulations state in part: “At the time of initial assignment and at least annually thereafter, the employer shall instruct every employee in the safe operation and servicing of all equipment with which the employee is, or will be involved.” These will include (but are not limited to) instructions to:

Keep all guards in place when the machine is in operation;

Permit no riders on equipment;

Stop engine, disconnect the power source, and wait for all machine movement to stop before servicing, adjusting, cleaning or unclogging the equipment, except where the machine must be running to be properly serviced or maintained, in which case the employer shall instruct employees as to all steps and procedures which are necessary to safely service or maintain the equipment.

Make sure everyone is clear of machinery before starting the engine, engaging power, or operating the machine.

EMPLOYEE TRACTOR OPERATING INSTRUCTIONS:

1. Securely fasten your seat belt if the tractor has a ROPS.
2. Where possible, avoid operating the tractor near ditches, embankments, and holes.
3. Reduce speed when turning, crossing slopes, and on rough, slick, or muddy surfaces.
4. Stay off slopes too steep for safe operation.
5. Watch where you are going, especially at row ends, on roads, and around trees.
6. Do not permit others to ride.
7. Operate the tractor smoothly - no jerky turns, starts, or stops.
8. Hitch only to the drawbar and hitch points recommended by tractor manufacturers.
9. When tractor is stopped, set brakes securely and use park lock if available.

Child Labor Under 16 Years Old

Some regulations specify that no one under the age of 16 may operate power machinery. It is your responsibility to know what these regulations are in your own area or situation. (Refer to U.S. Dept. of Labor, Employment Standard Administration, Wage & Home Division, Child Labor Bulletin #102.)

SECTION I

INTRODUCTION AND DESCRIPTION

1-1 INTRODUCTION

We are pleased to have you as a Bush Hog customer. Your 325, 326 or 327 Series Rotary Cutter has been carefully designed to give maximum service with minimum down time. This manual is provided to give you the necessary operating and maintenance instructions for keeping your rotary cutter in top operating condition. Please read this manual thoroughly. Understand what each control is for and how to use it. Observe all safety precautions decal on the machine and noted throughout the manual for safe operation of implement. If any assistance or additional information is needed, contact your authorized Bush Hog dealer.

1-2 DESCRIPTION

The 325, 326, 327 Series rotary cutters (Figure 1-1) are designed for heavy duty applications such as cutting thick grass, heavy brush and small trees. These cutters are single spindle with two free-swinging blades. Free-swinging blades reduce the shock of impact when a stationary object is hit. Additional protection is provided by a slip clutch on the gearbox input shaft. A round blade holder allows the cutter to "ride over" stumps and similar immovable objects. Models 325, and 326 are attached to the tractor using standard Cat. I or II 3-point hitches or Cat. I or II quick hitch adaptors. Model 327 is attached to the tractor using Cat. II or III standard 3-point hitches or Cat. II or III quick hitch adaptors. The 327 is also available as a pull type. Standard equipment includes driveline shields, clutch shields and front and rear discharge shields (deflectors).

Figure 1-1 Major Components

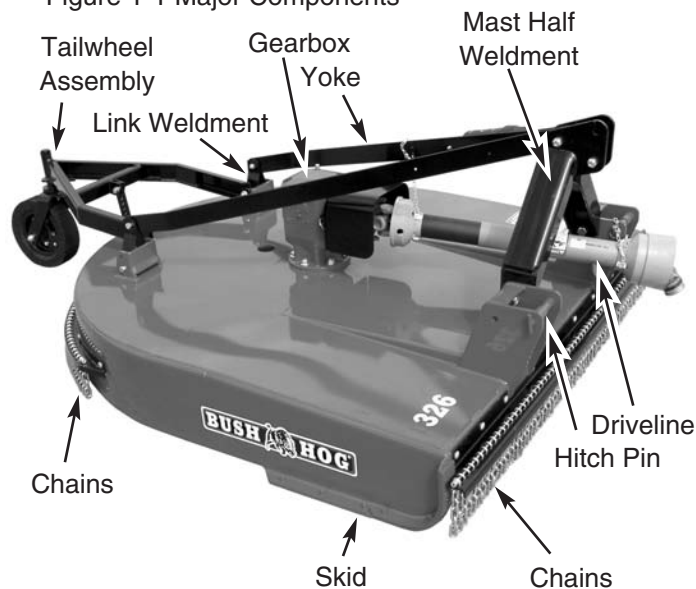

NOTE: Dealer or purchaser may elect to delete front and rear discharge shields (deflectors) at their option. Refer to "WARNING" in Section 3-3.

NOTE

All references made to right, left, front, rear, top or bottom are as viewed facing the direction of forward travel with implement properly attached to tractor.

Table 1 Technical Specifications

| SERIES | 325 | 326 | 327 |
|---------------------------|--|--|--------------------------------------|
| Cutting Width | 60" | 72" | 84" |
| Transport Width | 66" | 78" | 90" |
| Length | 107 1/2" | 118-1/2" | 182" (Pull), 131" (Lift) |
| Hitch | 3-Point Cat. I and Cat. II standard & Quick Hitch | 3-Point Cat. II and III standard & Quick Hitch | Also Available as Pull Type |
| Cutting Height | 2" - 12" | 2" - 12" | 2" - 12" |
| Cutting Capacity | 3-1/2" Diameter | 3-1/2" Diameter | 3-1/2" Diameter |
| Driveshaft | ASAE Category 5 | ASAE Category 5 | ASAE Category 5 |
| Gearbox | 540 RPM (190 HP) | 540 RPM (190 HP) | 540 RPM (190 HP) |
| Blades | 1/2" x 4" Uplift | 1/2" x 4" Uplift | 1/2" x 4" Uplift |
| Blade Tip Speed | 13,572 fpm | 13,996 fpm | 11,875 fpm |
| Blade Holder | Round | Round | Round |
| Top Deck | 7 Ga. Steel | 7 Ga. Steel | 7 Ga. Steel |
| Side Bands | 1/4" x 12-1/2" | 1/4" x 12-1/2" | 1/4" x 12-1/2" |
| Minimum Tractor HP | 50 | 60 | 70 (Lift); 50(Pull) |
| Front & Rear Deflectors | Front belting & rear bands are standard, chains are optional | | |
| Wheels | Laminated | Laminated | Laminated |
| Approximate Weight (lbs.) | 1285 lbs. * | 1507 lbs. * | 2043 lbs. (Lift)*; 2256 lbs. (Pull)* |

*Weight includes front and rear chains.

SPECIFICATIONS SUBJECT TO CHANGE WITHOUT NOTICE

SECTION II

PREPARATION FOR USE

2-1 ATTACHING TO TRACTOR

⚠ WARNING

NEVER STAND BETWEEN TRACTOR AND CUTTER WHILE TRACTOR IS BEING BACKED TO HITCH.

⚠ WARNING

ADDITIONAL TRACTOR FRONT BALLAST MAY BE NEEDED FOR STABLE OPERATION AND TRANSPORT OF THE 3-POINT HITCH MOUNTED CUTTER. SEE TRACTOR OPERATOR'S MANUAL FOR RECOMMENDED WEIGHTS.

⚠ WARNING

DO NOT USE PTO SHAFT ADAPTERS TO CHANGE SIZE OF TRACTOR PTO SHAFT. THE CORRECT DRIVELINE MUST BE USED TO MATCH TRACTOR PTO SHAFT.

A. Arrange hitch pins and bushings on heavy duty hitches as shown in Figures 2-1 and 2-2 depending on your tractor and hitch type.

B. Attach cutter to tractor 3-point hitch per tractor operator's manual. Do not attach driveline at this time.

C. Raise 3-point hitch until front of cutter is approximately 1-2 inches (25-51mm) lower than rear for standard cut or until front of cutter is 1 inch (25mm) higher than rear for extra shredding. Shut down

tractor. Securely block cutter in position. For further explanation of cutter adjustment, see **Section 3-2**.

NOTE

Due to the many variations in tractor / implement hitch points and corresponding differences in distances between tractor PTO shafts and implement input shafts, drivelines may need to be shortened as described in the following steps:

D. Raise and lower cutter to determine position with shortest distance between the tractor PTO shaft and gearbox input shaft. Shut down tractor leaving cutter in position of shortest distance. **Securely block cutter in position.**

E. Pull driveline apart. Attach outer (female) section to tractor PTO shaft. Pull on driveline section to be sure that yoke locks into place.

F. Hold driveline sections parallel to each other to determine if too long. Each section should end approximately 3 inches (76mm) short of reaching universal joint shield on opposite section. If too long, measure 3 inches (76mm) back from universal joint shield and mark on opposite section. (Figure 2-3). Do this for both sections.

G. Raise and lower cutter to determine position with greatest distance between PTO shaft and gearbox input shaft. Shut down tractor leaving cutter in position of greatest distance. **Securely block cutter in position.**

Setup for lower hitch point spacers

Figure 2-1
Models 325 & 326

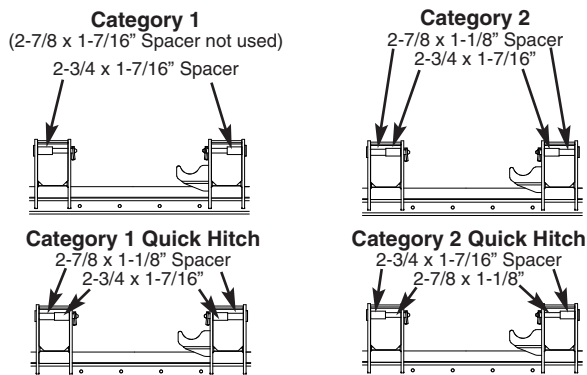

Figure 2-2
Model 327

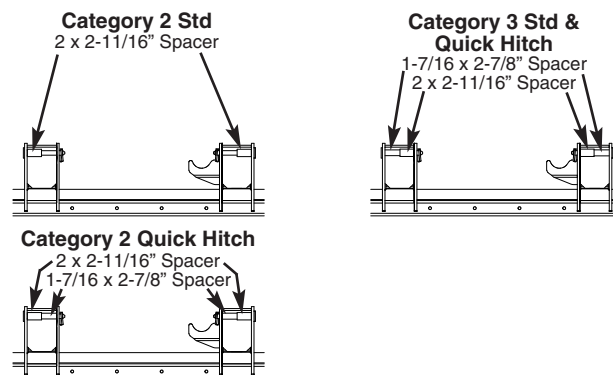
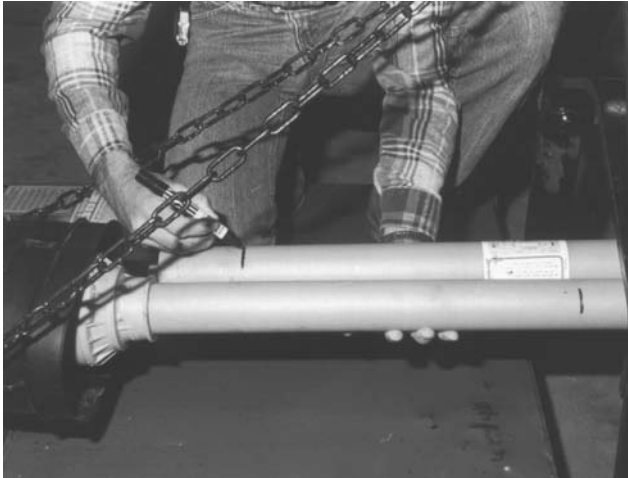
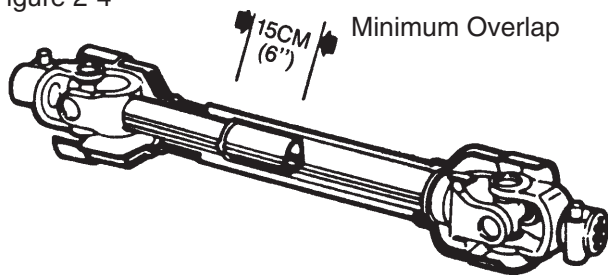

Figure 2-3



H. Hold driveline sections parallel to each other and check for minimum 6 inches (15cm) overlap. Figure 2-4). If driveline has been marked for cutting, overlap will be the distance between two marks. If driveline has less than minimum overlap, do not use. Contact authorized Bush Hog dealer.

Figure 2-4



NOTE

If driveline is the correct length, omit the following steps "I" through "L" and proceed to step "M".

I. Clamp driveline in a well padded vice to prevent damage to the shield. Cut off shield where marked. (Figure 2-5)

Figure 2-5



J. Using cut off section of shield as a guide, cut shaft the same amount. (Figure 2-6)

Figure 2-6



K. Repeat steps "I" and "J" to other driveline section.

L. Deburr ends of driveline sections and clean away all chips and filings. (Figure 2-7)

Figure 2-7



M. Apply multi-purpose grease to inside of outer (female) driveline section. Assemble driveline and install on tractor and cutter. Pull on each driveline section to be sure yokes lock into place. Make certain driveline shielding is in place and in good condition.

N. Adjust lower lift arm(s) to level cutter right to left. Refer to tractor operator's manual for instructions.

NOTE

After attaching driveline to tractor, attach driveline shield chains from both ends of driveline shielding to stationary locations.

SECTION III

OPERATING INSTRUCTIONS

3-1 GENERAL SAFETY

Only qualified people should operate this machine. Operator should wear hard hat, safety glasses and safety shoes. Use ROPS (Rollover Protective Structures) and seat belt equipped tractors for mowing operations. Before beginning operation, clear work area of objects that may be picked up and thrown. Check for ditches, stumps, holes or other obstacles that could upset tractor or damage cutter. Always turn off tractor engine, set parking brake, and allow cutter blades to come to a complete stop before dismounting tractor.

3-2 ADJUSTING FOR WORK

The cutter should be operated at the highest position which will give desired cutting results. This will help prevent the blades from striking the ground, reducing blade wear and undue strain on the machine. For best results under heavier cutting conditions, tilt the cutter approximately 1-2 inches (25-51mm) lower in the front. This tilt decreases horsepower requirements and increases potential ground speed. When fine shredding is desired, adjust cutter deck level or slightly lower in the rear. This will keep the foliage under cutter until thoroughly shredded. More power is required for shredding.

3-2.1 CUTTING HEIGHT ADJUSTMENT

(Three Point Lift Models)

⚠ WARNING

THE CUTTER CAN FALL FROM HYDRAULIC SYSTEM FAILURE. TO AVOID SERIOUS INJURY OR DEATH, SECURELY SUPPORT CUTTER BEFORE WORKING UNDERNEATH.

⚠ WARNING

AVOID PLACING HANDS, FEET OR ANY OTHER BODY PARTS BENEATH THE CUTTER WHILE MAKING HEIGHT ADJUSTMENTS.

The cutting height may be adjusted from 2" to 12" by selecting the appropriate hole in the adjustment bar between the tailwheel frame and deck lugs.(Figure 3-1)

- Raise cutter using 3-point lift until tailwheel lifts off ground. Turn off tractor. Block cutter in position.
- Remove adjusting bolt from bracket.
- Position tailwheel for desired cutting height.
- Replace adjusting bolt and tighten securely.

3-3 OPERATION

- Perform **BEFORE EACH USE** maintenance listed in Section 4-1.
- Start tractor.
- With tractor at idle speed, engage PTO drive.
- Adjust cutter to working position.

⚠ DANGER

STAY CLEAR OF ROTATING DRIVELINE. DO NOT OPERATE WITHOUT DRIVELINE SHIELDS IN PLACE AND IN GOOD CONDITION. FAILURE TO HEED THESE WARNINGS MAY RESULT IN PERSONAL INJURY OR DEATH.

- Set tractor throttle for appropriate PTO speed (540 RPM).

Figure 3-1 Tailwheel Height Adjustment

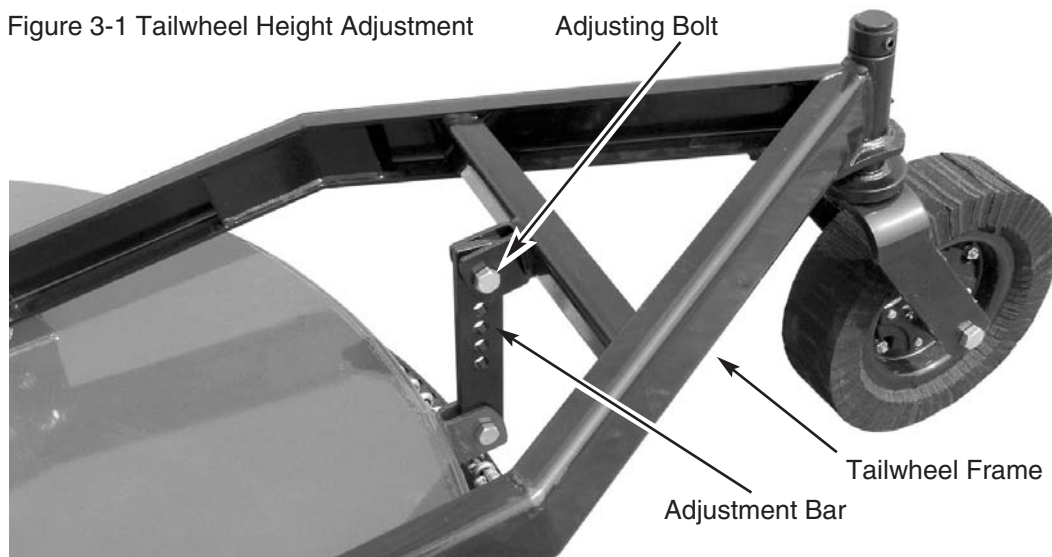

 **DANGER**

ROTATING CUTTER BLADES. STAND CLEAR UNTIL ALL MOTION HAS STOPPED. TO AVOID AN ACCIDENTAL FALL FROM THE TRACTOR AND POSSIBLE INJURY BY THE MOWER, IT IS RECOMMENDED THAT THE TRACTOR BE EQUIPPED WITH ROPS (ROLLOVER PROTECTIVE SYSTEM) AND THAT A SEAT BELT BE USED BY THE OPERATOR FOR ALL MOWING OPERATIONS.

F. Place tractor in gear and begin cutting. **Tractor forward speed should be controlled by gear selection, not engine speed.** For maximum cutting efficiency, forward speed should allow cutter to maintain a constant, maximum blade speed. Do not exceed 5 mph (8kph). If PTO drive is disengaged due to cutter stalling or tractor engine bogging, cutter must be moved to a "cut" area and tractor throttle reduced to idle before re-engaging. Always cut up and down the face of slopes, never across.

 **WARNING**

ALL ROTARY CUTTERS HAVE THE ABILITY TO DISCHARGE OBJECTS AT HIGH SPEEDS WHICH COULD RESULT IN SERIOUS INJURY TO BYSTANDERS OR PASSERS-BY.

THEREFORE, THIS CUTTER IS NOT TO BE OPERATED ALONG HIGHWAYS OR IN ANY AREA WHERE PEOPLE MAY BE PRESENT UNLESS ALL SIDES OF THE UNIT ARE ENCLOSED BY PERMANENT BANDS, SAFETY CHAINS, OR OTHER FACTORY APPROVED SAFETY SHIELDS THAT ARE IN GOOD REPAIR. CEASE MOWING WHENEVER ANYONE COMES WITHIN THE OPERATING AREA.

3-4 TRANSPORTING

When implement is transported on road or highway, day or night, use tractor flashing warning lights unless prohibited by law. A slow moving vehicle (SMV) sign must be visible from the rear by approaching vehicles. Do not exceed 15 mph (24kph) when traveling. Fully raise implement before transporting.

SECTION IV MAINTENANCE

4-1 MAINTENANCE CHECK LIST

Perform scheduled maintenance as outlined below. Lower machine to ground, turn off tractor and set parking brake before doing maintenance inspections or work. Some checks may require raising machine off ground and supporting with blocks. All bolts should be torqued as recommended in the torque specifications chart unless otherwise indicated.

 **WARNING**

THE CUTTER CAN FALL FROM HYDRAULIC SYSTEM FAILURE. TO AVOID SERIOUS INJURY OR DEATH, SECURELY SUPPORT CUTTER BEFORE WORKING UNDERNEATH.

BEFORE EACH USE

1. Check tractor tire air pressure. Refer to tractor operator's manual.
2. Check blades and spindle to be sure that no foreign objects such as wire or steel strapping bands are wrapped around them.
3. Check blade bolts for tightness. **Tighten to 450 ft./lbs. (610 Nm).**
4. Inspect blades for wear. Replace if necessary per paragraph 4-4. **Always replace both blades on spindle with two blades equal in weight. Use only genuine Bush Hog replacement parts.**
5. Make certain driveline shields are in place and in good repair to minimize entanglement injuries to persons by rotating drivelines.
6. Make certain deflector shields (chains, bands, etc.) are in good repair to minimize injuries to persons by the discharge of high speed thrown objects.

7. Inspect wheel(s) for wear, damage, or foreign objects. Repair or replace if necessary.
8. Perform BEFORE EACH USE lubrication per paragraph 4-2.
9. During operation, listen for abnormal sounds which might indicate loose parts, damaged bearings or other damage.

AFTER EACH USE

1. Clean all debris from machine especially underside of deck and affixed safety decals. Replace any missing or illegible decals.
2. Inspect cutter for worn or damaged components. Repair/replace before next use. Any replacement components installed during repair shall include the component's current safety decals specified by the manufacturer to be affixed to the component.
3. Store cutter in a dry place.

4-2 LUBRICATION (Figure 4-1)

NOTE

The multi-purpose grease referenced in this section is an NLGI Grade 2 type grease.

BEFORE EACH USE

1. Driveline Universal Joints - Apply multi-purpose grease with grease gun.
2. Wheel Bearings-Apply multi-purpose grease with grease gun.
3. Wheel Pivots-Apply multi-purpose grease with grease gun.
4. Driveline Guard-Apply 2-3 shots of multi-purpose grease with grease gun to plastic fitting.

5. **PTO Driveline - Disconnect PTO driveline, pull the two sections apart, apply thin coat of multi-purpose grease to inside of outer (female) section. Reassemble sections and install. Pull each section to be sure driveline and shields are securely connected. Make certain PTO shielding is in good condition.**
6. **Gearbox - Add EP80W-90 gear oil as necessary to bring oil level to check plug on side of housing.**

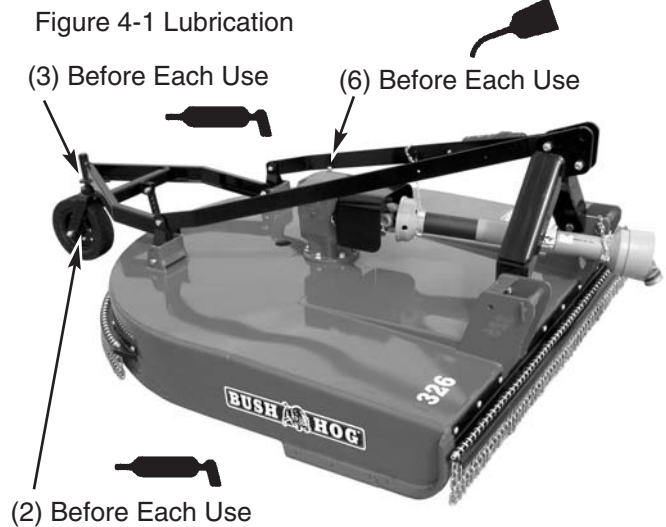
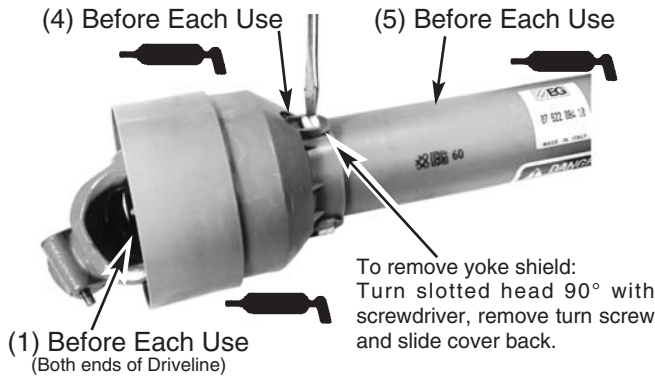

⚠ WARNING

THE CUTTER CAN FALL FROM HYDRAULIC SYSTEM FAILURE. TO AVOID SERIOUS INJURY OR DEATH, SECURELY SUPPORT CUTTER BEFORE WORKING UNDERNEATH.

4-3 BLADE HOLDER ASSEMBLY REMOVAL AND INSTALLATION

- A. Remove the lower shaft nut and lockwasher.
- B. Wearing heavy gloves, grasp blade holder and pull off tapered shaft. If stuck, align bolt with access hole in top of cutter deck. Using sledge hammer and a piece of pipe, strike blade bar. Rotate pan to the other blade bolt and strike blade bar. Repeat until blade holder comes off. Care should be taken not to damage blade bolt threads.

REPLACEMENT

- A. **Replace blade holder and tighten the lower shaft nut to 600 ft./lbs. If a torque wrench is not available, the nut should be tightened with a wrench having a three foot handle, or a section of pipe over the wrench handle, if a wrench of this size is not available.**
- B. Strike the blade holder several times with a heavy hammer and retighten lower shaft nut. This should be repeated several times.

4-4 BLADE REPLACEMENT (Figure 4-2)

It is not necessary to remove the complete blade holder assembly to replace the blades. Blade bolts are accessible through a hole in the top of the cutter deck. Always replace both blades on a spindle using two blades having the same weight. Use only genuine Bush Hog replacement parts.

- A. Raise cutter and securely block in position.

Figure 4-2 Blade Nut Removal



- B. Remove nuts from blade bolts using a 1-11/16" socket through the access hole in the deck.
- C. Inspect blade bolt shoulder for wear. Replace if necessary.

D. Assemble new blades to blade holder using blade bolts, nuts and lockwashers. **Tighten nuts to 450 ft./lbs.** Strike blade bolt head with heavy hammer to seat, then retighten.

E. **Check to be sure blades swing 360° freely. If blades will not swing freely, remove, locate problem, and repair. Operating cutter when blades will not swing freely will cause excessive vibration, damaging implement.**

4-5 SLIP CLUTCH OPERATIONAL CHECK

After implement had been stored for 30 days or more, perform the following operational check:

- A. Loosen eight nuts retaining clutch springs 1/3 turn or until springs can be turned with fingers.
- B. With tractor at idle speed, engage tractor PTO drive for 2-3 seconds. Clutch should slip without

turning blades. If clutch does not slip, contact your authorized Bush Hog dealer.

C. Retighten nuts to within 1/64" of original position. Initial spring length is shown in Figure 4-3.

⚠ WARNING

OVERTIGHTENING SPRING NUTS MAY CAUSE DAMAGE TO IMPLEMENT AND/OR TRACTOR DUE TO INCORRECT SLIP CLUTCH TORQUE SETTING. ALWAYS FOLLOW THE PROPER ADJUSTMENT PROCEDURE.

4-6 SLIP CLUTCH ADJUSTMENT

The slip clutch is factory preset to the correct torque for protecting implement and tractor. **Periodic adjustment is recommended**; refer to **Section 4-5**. Should adjustment be needed, first check to be sure all spring lengths are the same. Initial spring length is shown in Figure 4-3. If necessary, adjust nut on any spring that is unequal. Adjust all eight spring retaining nuts 1/3 of a turn (2 flats on a nut) and check clutch slippage. If further adjustment is necessary, do so in 1/3 turn increments. **Adjust only to provide sufficient torque to prevent slippage under normal conditions. Occasional slippage is normal for drivetrain protection.** If satisfactory results cannot be obtained, consult your Bush Hog dealer.

IMPORTANT

Do not overtighten nut and cause spring to become solid as this will cause shaft to fail.

4-7 GEARBOX MAINTENANCE

OIL LEVEL - The gearbox assembly on the 320 series rotary cutters are shipped from the factory less oil. Use EP80W-90 gear oil and fill to the check plug located on the side of the gearbox. Never fill the gear- box above this level. Seals could become damaged due to expansion.

OIL SEAL LEAKAGE - The three main causes of oil seal failure are as follows:

1. Operating cutter for any length of time with wire or litter wrapped around the upper or lower shaft.
2. Loose bearings.
3. Worn seals. Leaky seals should be replaced as soon as possible.

SEAL REPLACEMENT - To replace the seals on your cutter, follow the steps outlined below:

1. Remove the blade holder and universal joint.
2. Knock out old seals.
3. Install new seals.

Figure 4-3
Spring Length

CLUTCH SPRING LENGTH CHART

| Model | EG/Comer | Bondioli & Pavesi |
|-----------|----------------|-------------------|
| 325 & 326 | 1.27" (32.2mm) | 1.15" (29.3mm) |
| 327 | 1.28" (32.4mm) | 1.12" (28.5mm) |

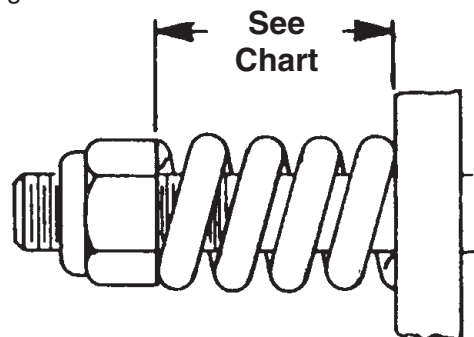



4-8 TROUBLESHOOTING

| PROBLEM | PROBABLE CAUSE | REMEDY |
|---------------------------------|---|--|
| Uneven Cut | Cutter not level side to side. | See SECTION II |
| | Worn or bent blades. | Replace blades per paragraph 4-4. |
| Stripping or Windrowing | Possible build-up of material under cutter. | Clean cutter. |
| | Cutter not level. | Refer to Section II. |
| | Worn blades. | Replace per paragraph 4-4. |
| Noisy Cutter | Loose components. | Check all bolts for tightness per Torque Chart. |
| | Low oil in gearboxes. | Check for proper oil level. Refer to paragraph 4-2. |
| Rapid Blade Wear (Cutting Edge) | Blade contacting the ground. | Adjust cutter to operate at a height that will eliminate ground contact. |
| Rapid Blade Wear (Bolt Hole) | Cutter not being operated at rated RPM speed. | Reduce ground speed. Set tractor throttle for proper PTO speed. |
| | Too much ground speed. | Use lower gear. |
| Poor Shredding Job | Incorrect deck tilt. | Adjust per paragraph 3-2. |
| | Excessive ground speed. | Reduce ground speed. |
| | Worn blades. | Replace blades per paragraph 4-4. |
| Cutter Vibration | Cutter not being operated at rated RPM speed. | Set tractor throttle for proper PTO speed. |
| | Possible build up of material on blade pan. | Clean blade pan. |
| | Broken blade. | Replace blades per paragraph 4-4. |
| | Blades unequal in weight. | Replace blades per paragraph 4-4. |

PRE-ASSEMBLY SAFETY PRECAUTIONS



THE FOLLOWING SAFETY PRECAUTIONS SHOULD BE THOROUGHLY UNDERSTOOD BEFORE ATTEMPTING MACHINE ASSEMBLY.

1. Wear personal protective equipment such as, but not limited to, protection for eyes, ears, feet, hands, lungs and head when assembling the equipment. Do not wear loose clothing or jewelry that may catch on equipment moving parts.
2. Do not lift heavy parts or assemblies. Use crane, jack, tackle, fork trucks or other mechanical devices.
3. Select an area for assembly that is clean and free of any debris which might cause persons working on the assembly to trip.
4. Arrange parts to be assembled neatly in the work area and have tools or other mechanical assisting devices in easy reach.
5. Inspect all parts and assemblies thoroughly and remove any sharp edges, grease, oil or dirt which might cause pieces to slip when handling.
6. Preview the assembly instructions in your operator's manual before proceeding further.
7. If the assembly instructions call for parts or assemblies to be blocked up, use only blocking material that is in good condition and is capable of handling the weight of the assembly to be blocked. Also, insure that the blocking material is on a clean, dry surface.
8. Never put hands or any other part of body under blocked up assemblies if at all possible.
9. Always wear goggles or safety glasses when hammering, grinding, or drilling metal parts.
10. If the assembly calls for welding or cutting, be sure that there are no flammable materials close at hand and that bystanders have taken necessary precautions.

AFTER COMPLETING ANY ASSEMBLY STEP, THOROUGHLY READ THE NEXT STEP IN THE ASSEMBLY INSTRUCTIONS BEFORE PROCEEDING WITH THAT STEP.

11. After completing assembly, thoroughly inspect the machine to be sure that all nuts, bolts, hydraulic fittings or any other fastened assemblies have been thoroughly tightened.
12. After completing assembly, be sure that all safety locking devices or guards are in place.
13. Before operating the machine, thoroughly read the operation section of this manual.
14. Before operating, read the maintenance section of this manual to be sure that any parts requiring lubrication have been properly lubricated.

BEFORE OPERATING THE EQUIPMENT, IF YOU HAVE ANY QUESTIONS REGARDING THE PROPER ASSEMBLY OR OPERATION, CONTACT YOUR AUTHORIZED BUSH HOG DEALER OR REPRESENTATIVE.

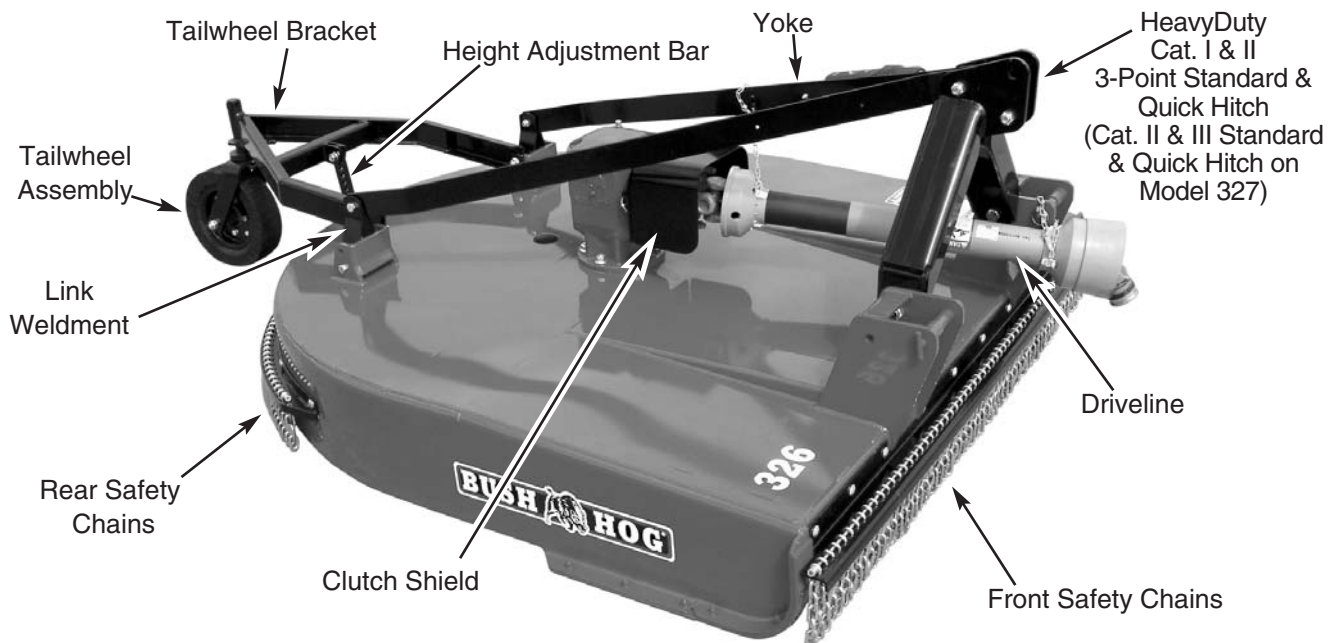

SECTION V ASSEMBLY

IMPORTANT

Tighten all fasteners to specifications on Torque Chart unless otherwise indicated.

5-1 MODELS 325 & 326

Reference Figure 5-1 for the following instructions:

A. Position tailwheel frame arms inside of deck lugs on cutter deck (behind gearbox). Secure tailwheel frame arms to deck lugs using 5/8" x 2" capscrews and flanged lock nuts (use upper holes on deck lugs). Lock nuts should be tightened completely and then backed-off ¼ to ½ turn to allow tailwheel frame to rotate for height adjustment.

B. Connect single-holed end of adjustment bar between the lugs at rear of cutter deck using 5/8" x 2" capscrew and locknut. (See Fig. 3-1, Page 9)

C. Rotate tailwheel frame into desired position and fasten tailwheel frame to nearest hole on adjustment bar using 5/8" x 2" capscrew, lock washer, and hex nut.

D. Install caster assembly by sliding shaft into bottom of tube on tailwheel frame weldment; secure shaft at the top of the tube using the lock collar and ½" x 2¼" roll pin provided with the caster assembly.

E. Install link spacer bushings inside of tubes on link weldments and attach the link weldments inside of deck lugs on cutter deck (behind gearbox) using ¾" x 7½" capscrews and lock nuts (use bottom holes on deck lugs).

F. Orient yokes with longer bent portion pointing toward rear of cutter and offset bends oriented so that the short bent portion lies near the front center of cutter. Attach the rear of left hand (LH) yoke

to the link weldment using yoke bushing (installed in hole on yoke), 5/8" x 2" capscrew, and lock nut. Repeat for right hand (RH) yoke.

G. Orient the LH mast weldment so that the multi-holed end of the part is toward the front center of the cutter. Install the lower, single-holed end of the LH mast weldment to the inside of the LH lower hitch lug on deck using strut bushing (installed in hole on mast weldment), 7/8" SAE flat washer, 7/8" x 2½" capscrew, and lock nut. Flat washer should be positioned on the inside of the mast weldment between the strut bushing and the head of the capscrew. Repeat for RH mast weldment.

H. Place free ends of yokes back-to-back and install mast spacer bushing through the holes of both yokes. Slide a yoke spacer bushing onto the mast spacer bushing on either side of yokes. Bring this assembly up in between the LH and RH mast weldments, aligning the mast spacer bushing with the rear upper holes on the weldments. Secure using a ¾" x 4" capscrew and lock nut.

I. Install the quick hitch top bushing between the mast weldments at the front lower holes of the weldments. Secure using a ¾" x 4" capscrew and lock nut.

J. Hold two lower hitch spacer bushings (one of each size) between front upper holes on hitch lugs on LH side of deck. Insert pin weldment from outside of cutter through outer lug, spacer bushings, and inner lug. Secure pin weldment using 7/16" x 1¾" klik pin. Repeat for RH side of cutter. (Fig. 2-1)

K. Attach operator's manual tube to LH yoke using 5/16" x 1¼" capscrews, flat washers, and lock nuts. Flat washers should be placed between the mounting feet on the operator's manual tube and the head of the capscrews.

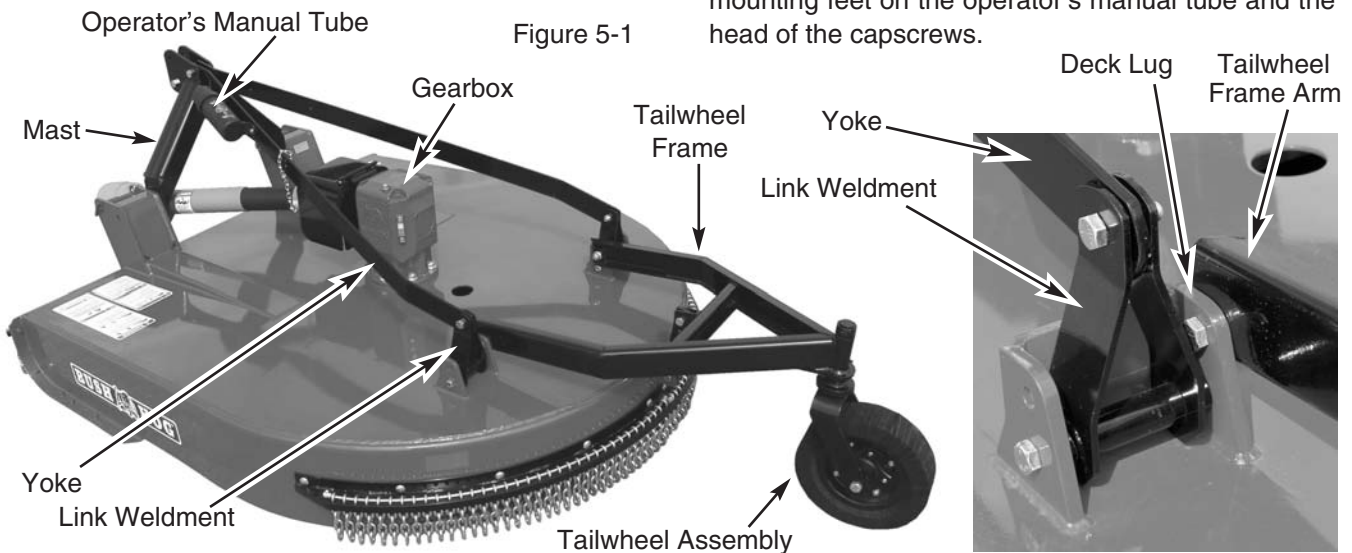

L. Attach driveline clutch shield to gearbox as shown in exploded view in Figure 5-4.

M. Remove tapered pin from splined clutch hub on end of driveline. Rotate clutch shield up over gearbox to expose gearbox input shaft.

N. Slide clutch hub onto gearbox input shaft aligning tapered pin holes on driveline clutch hub with groove on gearbox input shaft. Install tapered pin, washer, and nut. Torque nut to 30 ft-lbs. Attach driveline shield chain to a fixed point on the cutter to prevent rotation of shielding.

O. Loosen eight (8) nuts retaining clutch springs by 1/3 of a turn or until springs can be turned with fingers.

P. Connect cutter to tractor's 3-point hitch, attaching top link in top holes of mast weldments using customer-supplied pin. Attach lower link arms to cutter deck using the pins and bushings supplied with the cutter. Refer to Figure 2-1, Page 7 for the correct setup.

Q. Connect free end of driveline to tractor PTO shaft by pulling back on collar on driveline yoke and then sliding yoke onto PTO shaft. Release collar and slide driveline yoke back and forth on shaft until an audible click is heard (ball collar has seated in groove on PTO shaft). Attach driveline shield chain to a fixed point on the tractor to prevent rotation of shielding.

R. Start tractor and allow tractor to idle. With tractor at idle speed, engage tractor PTO drive for 2-3 seconds. Clutch should slip without turning cutter blades.

S. Disengage tractor PTO and turn off tractor ignition. Re-tighten nuts on clutch springs to their original position. Adjust nut position, if required, referring to **Section 4-6**.

 **WARNING**

OVER-TIGHTENING SPRING NUTS MAY CAUSE DAMAGE TO IMPLEMENT AND/OR TRACTOR DUE TO INCORRECT SLIP CLUTCH TORQUE SETTING. ALWAYS FOLLOW THE PROPER ADJUSTMENT PROCEDURE.

T. Remove filler plug on top of gearbox housing and oil level check plug on right side of housing. Fill gearbox with EP80W-90 gear oil until oil just reaches bottom of level plug hole. Allow time for oil to seep through bearings into lower housing of gearbox. Replace filler plug on top of gearbox with breather plug supplied in Owner's Manual Package.

5-2 MODEL 327 LIFT STYLE

Reference Figure 5-2 for the following instructions:

A. Remove shipping strap and (2) 1" x 2" cap-screws and lock nuts from axle attaching lug and attaching lug on cutter deck. Strap and fasteners may be discarded.

B. Attach axle height control means (either ratchet assembly or hydraulic cylinder assembly) between attaching lug on cutter deck and attaching lug on axle weldment using clevis pins and clips (ratchet) or cotter pins (cylinder) supplied with individual assembly. If using hydraulic cylinder, base end of cylinder should be mounted on deck lug with ports facing upwards.

1) Hydraulic cylinder plumbing:

a) Remove plug from rod end port and install supplied breather plug

b) Remove plug from base end port and install supplied 90° elbow fitting

c) Attach one end of supplied hydraulic hose to elbow fitting (other end attaches to tractor using one of the 2 supplied adapter fittings)

d) Use supplied "doughnut" cylinder stops (2 each 1" thick, 1 each 1¼" thick, 2 each 1½" thick, and 2 each 1¾" thick) to adjust cutting height of unit by raising unit fully up, installing doughnuts on cylinder rod, and then releasing hydraulic pressure – use different combinations of doughnut thicknesses to achieve desired height

C. Position heavy duty (HD) lift arm assembly on LH end of axle tube with a backup plate directly across from mounting plate on HD arm assembly on opposite side of axle tube. Clamp these items together on axle tube using (4) ¾" x 5½" capscrews (Grade 8), lock washers, and hex nuts. Repeat for RH end of axle.

D. Install a laminated wheel assembly onto the hub of the LH HD lift arm assembly. Secure the wheel to the threaded holes in the hub using (4) ½" x 1" capscrews and lock washers. Repeat for the RH HD lift arm assembly.

E. Install link spacer bushings inside of tubes on link weldments and attach the link weldments inside of deck lugs on cutter deck (behind gearbox) using $\frac{3}{4}$ " x $7\frac{1}{2}$ " capscrews and lock nuts (use front holes on deck lugs).

F. Orient yokes with longer bent portion pointing toward rear of cutter and offset bends oriented so that the short bent portion lies near the front center of cutter. Attach the rear of LH yoke to the link weldment using yoke bushing (installed in hole on yoke), $\frac{5}{8}$ " x 2" capscrew, and lock nut. Repeat for RH yoke.

G. Orient the LH mast weldment so that the multi-holed end of the part is toward the front center of the cutter. Install the lower, single-holed end of the LH mast weldment to the inside of the LH lower hitch lug on deck using strut bushing (installed in hole on mast weldment), $\frac{7}{8}$ " SAE flat washer, $\frac{7}{8}$ " x $2\frac{1}{2}$ " capscrew, and lock nut. Flat washer should be positioned on the inside of the mast weldment between the strut bushing and the head of the capscrew. Repeat for RH mast weldment.

H. Place free ends of yokes back-to-back and install mast space bushing through the holes of both yokes. Slide a yoke spacer bushing onto the mast spacer bushing on either side of yokes. Bring this assembly up in between the LH and RH mast weldments, aligning the mast spacer bushing with the rear upper holes on the weldments. Secure using a $\frac{3}{4}$ " x 4" capscrew and lock nut.

I. Install the quick hitch top bushing between the mast weldments at the front lower holes of the weldments. Secure using a 1" x $4\frac{1}{2}$ " capscrew, lock washer, and hex nut.

J. Hold two lower hitch spacer bushings (one of each size) between front upper holes on hitch lugs on LH side of deck. Insert hitch pin weldment from outside of cutter through outer lug, spacer bushings, and inner lug. Secure pin weldment using

$\frac{7}{16}$ " x $1\frac{3}{4}$ " klik pin. Repeat for RH side of cutter. (See Fig. 2-2, Page 7)

K. Attach operator's manual tube to LH yoke using $\frac{5}{16}$ " x $1\frac{1}{4}$ " capscrews, flat washers, and lock nuts. Flat washers should be placed between the mounting feet on the operator's manual tube and the head of the capscrews.

L. Attach driveline clutch shield to gearbox as shown in exploded view in Figure 5-4.

M. Remove tapered pin from splined clutch hub on end of driveline. Rotate clutch shield up over gearbox to expose gearbox input shaft.

N. Slide clutch hub onto gearbox input shaft aligning tapered pin holes on driveline clutch hub with groove on gearbox input shaft. Install tapered pin, washer, and nut. Torque nut to 30 ft-lbs. Attach driveline shield chain to a fixed point on the cutter to prevent rotation of shielding.

O. Loosen eight (8) nuts retaining clutch springs by $\frac{1}{3}$ of a turn or until springs can be turned with fingers.

P. Connect cutter to tractor's 3-point hitch, attaching top link in top or middle holes of mast weldments using customer-supplied pin. Attach lower link arms to cutter deck using the pins and bushings supplied with the cutter. Refer to Figure 2-2, Page 7 for the correct setup.

Q. Connect free end of driveline to tractor PTO shaft by pulling back on collar on driveline yoke and then sliding yoke onto PTO shaft. Release collar and slide driveline yoke back and forth on shaft until an audible click is heard (ball collar has seated in groove on PTO shaft). Attach driveline shield chain to a fixed point on the tractor to prevent rotation of shielding.

Figure 5-2 Model 327 Lift Type

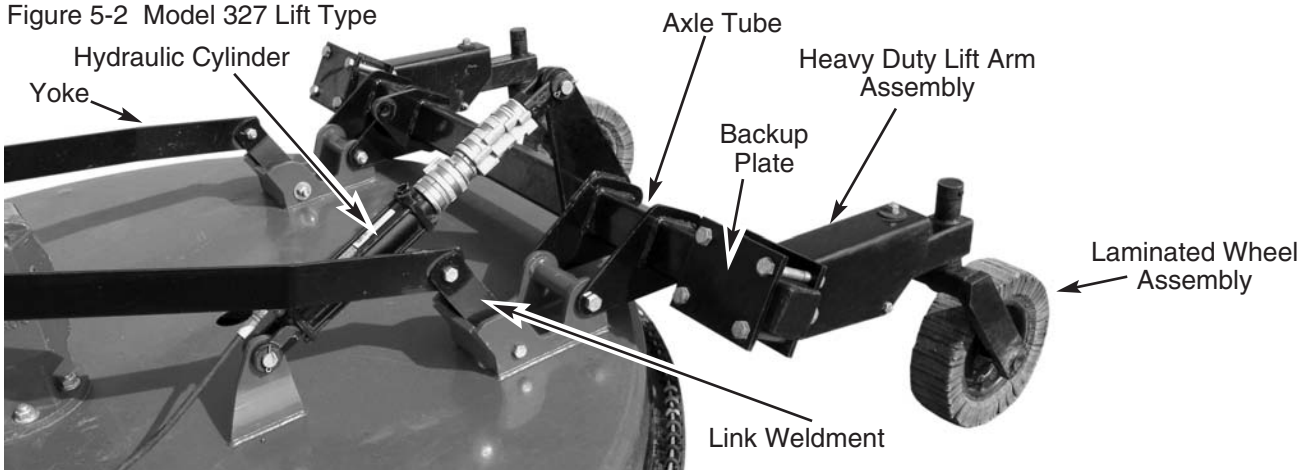

R. Start tractor and allow tractor to idle. With tractor at idle speed, engage tractor PTO drive for 2-3 seconds. Clutch should slip without turning cutter blades.

S. Disengage tractor PTO and turn off tractor ignition. Re-tighten nuts on clutch springs to their original position. Adjust nut position, if required, referring to Section 4-6.

⚠ WARNING

OVER-TIGHTENING SPRING NUTS MAY CAUSE DAMAGE TO IMPLEMENT AND/OR TRACTOR DUE TO INCORRECT SLIP CLUTCH TORQUE SETTING. ALWAYS FOLLOW THE PROPER ADJUSTMENT PROCEDURE.

T. Remove filler plug on top of gearbox housing and oil level check plug on right side of housing. Fill gearbox with EP80W-90 gear oil until oil just reaches bottom of level plug hole. Allow time for oil to seep through bearings into lower housing of gearbox. Replace filler plug on top of gearbox with breather plug supplied in Owner's Manual Package.

5-3 MODEL 327 PULL STYLE

Reference Figure 5-3 for the following instructions:

A. Remove shipping strap and (2) 1" x 2" cap-screws and lock nuts from axle attaching lug and attaching lug on cutter deck. Strap and fasteners may be discarded.

B. Attach axle height control means (either ratchet assembly or hydraulic cylinder assembly) between attaching lug on cutter deck and attaching

lug on axle weldment using clevis pins and clips (ratchet) or cotter pins (cylinder) supplied with individual assembly. If using hydraulic cylinder, base end of cylinder should be mounted on deck lug.

Hydraulic cylinder plumbing:

- Remove plug from rod end port and install supplied breather plug
- Remove plug from base end port and install supplied 90° elbow fitting
- Attach one end of supplied hydraulic hose to elbow fitting (other end attaches to tractor using one of the 2 supplied adapter fittings)
- Use supplied "doughnut" cylinder stops (2 each 1" thick, 1 each 1¼" thick, 2 each 1½" thick, and 2 each 1¾" thick) to adjust cutting height of unit by raising unit fully up, installing doughnuts on cylinder rod, and then releasing hydraulic pressure – use different combinations of doughnut thicknesses to achieve desired height

C. Position LH HD single axle arm assembly on LH end of axle tube with a backup plate directly across from mounting plate on HD arm assembly on opposite side of axle tube. Clamp these items together on axle tube using (4) ¾" x 5½" capscrews (Grade 8), lock washers, and hex nuts. Repeat for RH end of axle using RH HD single axle arm assembly.

D. Remove the (5) ½" lug nuts from the hub on the LH HD single axle arm assembly and install a laminated wheel assembly onto the hub over the protruding bolt threads. Secure the wheel to the hub by reinstalling the ½" lug nuts. Repeat for the RH HD axle arm assembly.

E. Insert 2 drawbar bushings into the tubes on the tongue assembly. Attach tongue assembly and bushings between the 2 sets of lower hitch lugs at the front lower hitch lug holes using 1" x 8" cap-screws and lock nuts.

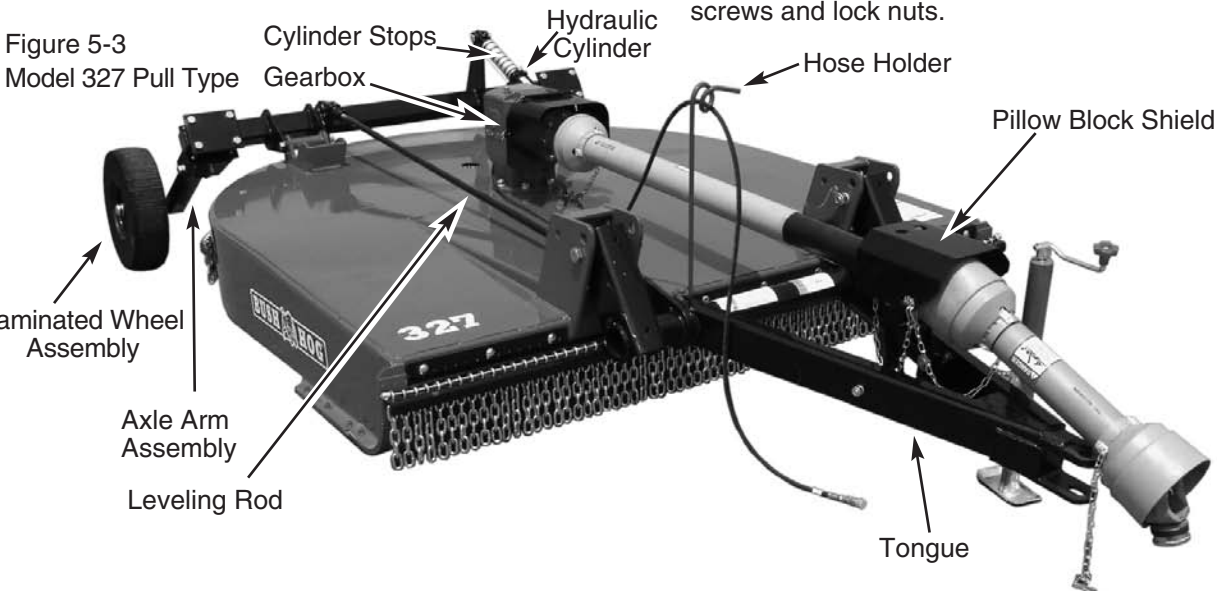

Figure 5-3
Model 327 Pull Type

F. Attach leveling rod assembly between attaching lug on axle weldment and attaching lug on tongue assembly on LH side of cutter. Secure ends through holes in the attaching lugs using the clevis pins and cotter pins supplied with the leveling rod assembly. Repeat for RH side of cutter.

PILLOW BLOCK ASSEMBLY MOUNTING

G. Install the bearing support weldment between the channel arms of the tongue assembly with the ears on the support weldment oriented upwards. Secure the support weldment to the tongue assembly on either side using (2) 5/8" x 1 1/2" capscrews, 5/8" SAE flat washers, and lock nuts.

H. Install pivot spacer bushing into tube on pillow block spacer weldment and attach spacer weldment to bearing support weldment ears using 3/4" x 9/16" capscrew, lock washer, and lock nut.

I. Attach bearing housing assembly to pillow block spacer weldment using pin weldment, 3/4" lock washer, and 3/4" lock nut.

J. Install jackshaft shield weldment on top of bearing housing assembly using (2) 1/2" x 1 1/4" capscrews and lock washers

K. Install hose holder assembly (for units using hydraulic height adjustment) at hole in tongue assembly channel side (LH or RH side, whichever is preferred) using provided 5/8" x 2" capscrew, flat washer, lock washer, and hex nut. Route free end of hydraulic hose through pigtail loop at top of hose holder and from there, attach hose to tractor hydraulic supply connection.

L. Attach driveline clutch shield to gearbox as shown in exploded view in Figure 5-4.

M. Remove tapered pin from splined clutch hub on end of telescoping jackshaft driveline. Rotate clutch shield up over gearbox to expose gearbox input shaft.

N. Slide clutch hub onto gearbox input shaft aligning tapered pin holes on driveline clutch hub with groove on gearbox input shaft. Install tapered pin, washer, and nut. Torque nut to 30 ft-lbs. Attach driveline shield chain to a fixed point on the cutter to prevent rotation of shielding.

O. Slide splined end of jackshaft through pillow block bearing housing until shoulder on jackshaft bottoms on bearing race. Slide lock collar over end of jackshaft and push collar firmly up against bearing race. Tighten set screw in lock collar. Attach driveline shield chain to a fixed point on the pillow block mounting assembly to prevent rotation of shielding.

P. Remove tapered pin from splined yoke on end of fixed-length Cardan driveline. Slide Cardan driveline yoke onto jackshaft aligning tapered pin holes in Cardan driveline yoke with groove on jackshaft. Install tapered pin, washer, and nut. Torque nut to 30 ft-lbs. Attach driveline shield chain to a fixed point on the pillow block mounting assembly to prevent rotation of the shielding.

Q. Loosen eight (8) nuts retaining clutch springs on jackshaft driveline by 1/3 of a turn or until springs can be turned with fingers.

R. Connect cutter's tongue to tractor's drawbar using customer-supplied drawbar pin. Connect free end of Cardan driveline to tractor PTO shaft by pulling back on collar on driveline yoke and then sliding yoke onto PTO shaft. Release collar and slide driveline yoke back and forth on shaft until an audible click is heard (ball collar has seated in groove on PTO shaft). Attach driveline shield chain to a fixed point on the tractor to prevent rotation of the shielding.

S. Start tractor and allow tractor to idle. With tractor at idle speed, engage tractor PTO drive for 2-3 seconds. Clutch should slip without turning cutter blades.

T. Disengage tractor PTO and turn off tractor ignition. Re-tighten nuts on clutch springs to their original position. Adjust nut position, if required, referring to **Section 4-6**.

⚠ WARNING

OVER-TIGHTENING SPRING NUTS MAY CAUSE DAMAGE TO IMPLEMENT AND/OR TRACTOR DUE TO INCORRECT SLIP CLUTCH TORQUE SETTING. ALWAYS FOLLOW THE PROPER ADJUSTMENT PROCEDURE.

U. Remove filler plug on top of gearbox housing and oil level check plug on right side of housing. Fill gearbox with EP80W-90 gear oil until oil just reaches bottom of level plug hole. Allow time for oil to seep through bearings into lower housing of gearbox.

Figure 5-4 Gearbox Input Shield

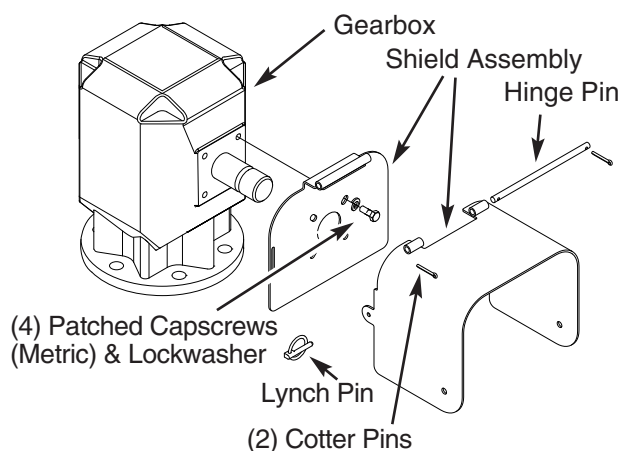

Replace filler plug on top of gearbox with breather plug supplied in Owner's Manual Package.

5-3 FRONT BELTING INSTALLATION (Fig. 5-5)

A. Align belting and center clamp with center (4) holes in front stiffener.

B. Fasten belting and center clamp using (4) ½" x 4" carriage bolts, lock washers, and hex nuts.

C. Align belting and side clamp with:

Model 325: (2) holes on LH side of front stiffener.

Models 326 & 327: (3) holes on LH side of front stiffener.

D. Fasten belting and side clamp using either (2) or (3) ½" x 4" carriage bolts, lock washers, and hex nuts depending on model listed in Step C above.

E. Repeat steps C and D from above for the RH side of front stiffener.

5-4 REAR BAND INSTALLATION (Fig. 5-5)

A. Align deflector band with holes in rear band of deck.

B. Fasten deflector band using:

Model 325: (8) ½" x 1¼" carriage bolts, lock washers, and lock nuts.

Models 326 & 327: (10) ½" x 1¼" carriage bolts, lock washers, and lock nuts.

5-5 FRONT CHAIN INSTALLATION (Fig. 5-6)

A. Align front chain assembly mounting bracket with holes in front stiffener.

B. Fasten chain mounting bracket using:

Model 325: (8) ½" x 4" carriage bolts, lock washers, and hex nuts.

Models 326 & 327: (10) ½" x 4" carriage bolts, lock washers, and hex nuts.

5-6 REAR CHAIN INSTALLATION (Fig. 5-6)

A. Align LH and RH rear chain assemblies with holes at rear of deck side bands.

B. Fasten LH and RH rear chain assemblies to side bands using:

Model 325: (8) ½" x 1¼" carriage bolts, lock washers, and lock nuts.

Models 326 & 327: (10) ½" x 1¼" carriage bolts, lock washers, and lock nuts.

⚠ CAUTION

USE ONLY FACTORY APPROVED CHAIN GUARDS.

⚠ WARNING

DEFLECTOR KIT OR CHAIN SHIELDING IS STANDARD EQUIPMENT. MUST BE USED FOR ALL NON-AGRICULTURAL USES OR IN AREAS WHERE THE POSSIBILITY OF THROWN OBJECTS COULD BE HAZARDOUS TO PERSONS OR PROPERTY. USE 5/16" DOUBLE ROW HIGHWAY CHAINS FOR ALL ROADSIDE MOWING OPERATIONS.

Figure 5-5 Front Belting & Rear Bands

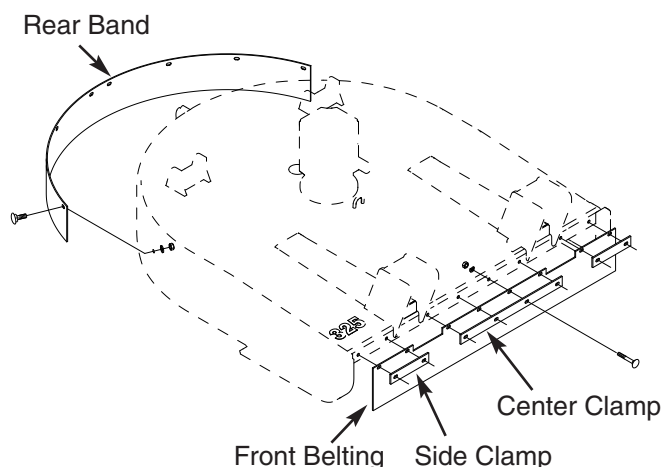
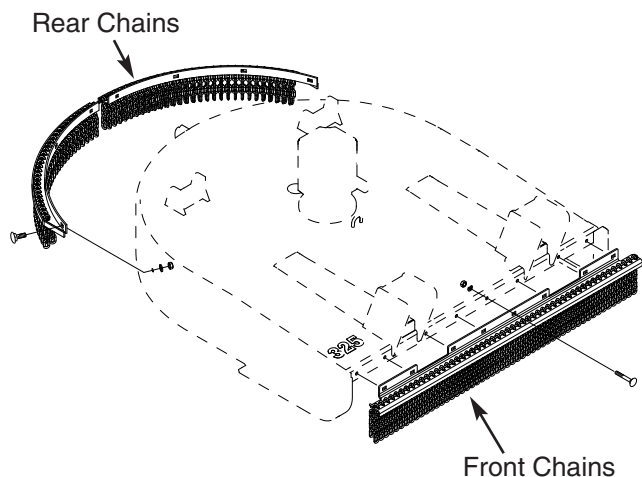

Figure 5-6 Front & Rear Chains



SAFETY DECALS

To promote safe operation, Bush Hog supplies safety decals on all products manufactured. Because damage can occur to safety decals either through shipment, use or reconditioning, Bush Hog will, upon request, provide safety decals for any of our products in the field at no charge. Contact your authorized Bush Hog dealer for more information.

⚠ DANGER

KEEP AWAY - ROTATING BLADES

TO AVOID SERIOUS INJURY OR DEATH FROM BLADE CONTACT:

- LOWER IMPLEMENT, STOP ENGINE AND PTO, ALLOW ALL MOVING PARTS TO STOP, AND REMOVE KEY BEFORE DISMOUNTING FROM TRACTOR.
- ALLOW NO RIDERS ON TRACTOR OR MOWER.
- KEEP ALL PERSONS CLEAR OF OPERATING MOWER AND MOWING AREA.
- KEEP CLEAR OF ROTATING BLADES, PARTS, AND DRIVELINES.

PREVENT FALL OFF INTO ROTATING BLADES

TO PREVENT ACCIDENTAL FALL OFF FROM TRACTOR AND SERIOUS INJURY OR DEATH FROM RUN OVER OR ROLLOVER BY TRACTOR OR MOWER:

- USE ROPS (ROLOVER PROTECTIVE STRUCTURES) AND SEAT BELT EQUIPPED TRACTORS FOR MOWING OPERATIONS.
- BUCKLE UP SEAT BELT.
- KEEP ALERT FOR STUMPS, HOLES, RUTS AND UNEVEN TERRAIN.

⚠ WARNING

ROTARY CUTTERS CAN DISCHARGE OBJECTS SEVERAL HUNDREDS OF FEET, TO AVOID SERIOUS INJURY OR DEATH TO BYSTANDERS FROM THROWN OBJECTS:

- CLEAR MOWING AREA OF VISIBLE DEBRIS AND USE EXTRA CAUTION WHERE ROCKS OR DEBRIS MAY BE PRESENT.
- DO NOT OPERATE CUTTER ALONG ROADWAYS OR IN THE VICINITY OF OTHER PERSONS WITHOUT ENCLOSED SIDES, PERMANENT BANDS, BELTING, HIGHWAY CHAINS OR OTHER FACTORY APPROVED DISCHARGE SHIELDS IN PLACE AND IN GOOD WORKING ORDER.
- KEEP ALL PERSONS WELL CLEAR OF MOWER WHEN IN OPERATION.

⚠ CAUTION

THIS IMPLEMENT IS DESIGNED TO OPERATE AT 540 RPM MAXIMUM TRACTOR PTO SPEED.

ALL DRIVE LINE SHIELDS MUST BE KEPT IN PLACE.

50029417

⚠ DANGER

ROTATING DRIVELINE CONTACT CAN CAUSE DEATH KEEP AWAY!

DO NOT OPERATE WITHOUT -

- ALL DRIVELINE GUARDS, TRACTOR AND EQUIPMENT SHIELDS IN PLACE
- DRIVELINES SECURELY ATTACHED AT BOTH ENDS
- DRIVELINE GUARDS THAT TURN FREELY ON DRIVELINE

BONDIOLI & PAVESI

78608

⚠ WARNING

TO AVOID SERIOUS INJURY OR DEATH:

- READ OPERATOR'S MANUAL BEFORE OPERATING AND FOLLOW ALL PRECAUTIONS. (CONTACT DEALER FOR MANUAL)
- KEEP SHIELDS AND GUARDS IN PLACE. KEEP CLEAR OF DRIVES AND BELTS.
- LOWER IMPLEMENT, STOP ENGINE AND PTO, ALLOW ALL MOVING PARTS TO STOP, AND REMOVE KEY BEFORE DISMOUNTING FROM TRACTOR.
- KNOW HOW TO STOP TRACTOR AND EQUIPMENT QUICKLY IN AN EMERGENCY.
- ALLOW NO CHILDREN OR UNQUALIFIED PERSONS TO OPERATE EQUIPMENT.
- BE CAREFUL ON UNEVEN TERRAIN. DECREASE SPEED WHEN TURNING.
- DO NOT OPERATE MOWER IN TRANSPORT POSITION.

⚠ WARNING

IMPLEMENT CAN FALL FROM HYDRAULIC SYSTEM RELEASE. TO AVOID SERIOUS INJURY OR DEATH:

- SHUT OFF TRACTOR ENGINE, REMOVE KEY, SECURE TRACTOR PARKING BRAKE AND BLOCK UP OR SECURELY SUPPORT IMPLEMENT BEFORE WORKING UNDERNEATH.
- PURGE ALL AIR FROM HYDRAULIC SYSTEM BEFORE ATTEMPTING TO RAISE OR LOWER THIS IMPLEMENT.
- STAND CLEAR IF LOWERING OR RAISING IMPLEMENT.
- DO NOT USE HAND OR SKIN TO CHECK FOR HYDRAULIC LEAKS. USE CARDBOARD OR WOOD.
- HIGH PRESSURE OIL LEAKS CAN PENETRATE SKIN CAUSING SERIOUS INJURY AND GANGRENE. CONSULT A PHYSICIAN IMMEDIATELY.
- LOWER THE IMPLEMENT AND RELEASE HYDRAULIC PRESSURE BEFORE LOOSENING FITTINGS.
- REFER TO OWNER'S MANUAL FOR DETAILS.

50029419

⚠ DANGER

GUARD MISSING DO NOT OPERATE

⚠ DANGER

GUARD MISSING DO NOT OPERATE

⚠ DANGER

78786

TORQUE SPECIFICATIONS

Proper torque for American fasteners used on Bush Hog equipment.
Recommended Torque in Foot Pounds (Newton Meters).*

AMERICAN

Bolt Head Markings

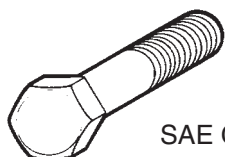

SAE Grade 2
(No Dashes)

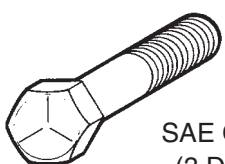

SAE Grade 5
(3 Dashes)

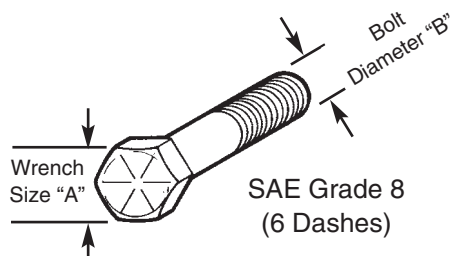

SAE Grade 8
(6 Dashes)

| WRENCH SIZE (IN.) "A" | BOLT DIAMETER (IN.) "B" AND THREAD SIZE | SAE GRADE 2 | SAE GRADE 5 | SAE GRADE 8 |
|-----------------------|---|-------------|-------------|-------------|
| 7/16 | 1/4 - 20 UNC | 6 (7) | 8 (11) | 12 (16) |
| 7/16 | 1/4 - 28 UNF | 6 (8) | 10 (13) | 14 (18) |
| 1/2 | 5/16 - 18 UNC | 11 (15) | 17 (23) | 25 (33) |
| 1/2 | 5/16 - 24 UNF | 13 (17) | 19 (26) | 27 (37) |
| 9/16 | 3/8 - 16 UNC | 20 (27) | 31 (42) | 44 (60) |
| 9/16 | 3/8 - 24 UNF | 23 (31) | 35 (47) | 49 (66) |
| 5/8 | 7/16 - 14 UNC | 32 (43) | 49 (66) | 70 (95) |
| 5/8 | 7/16 - 20 UNF | 36 (49) | 55 (75) | 78 (106) |
| 3/4 | 1/2 - 13 UNC | 49 (66) | 76 (103) | 106 (144) |
| 3/4 | 1/2 - 20 UNF | 55 (75) | 85 (115) | 120 (163) |
| 7/8 | 9/16 - 12 UNC | 70 (95) | 109 (148) | 153 (207) |
| 7/8 | 9/16 - 18 UNF | 79 (107) | 122 (165) | 172 (233) |
| 15/16 | 5/8 - 11 UNC | 97 (131) | 150 (203) | 212 (287) |
| 15/16 | 5/8 - 18 UNF | 110 (149) | 170 (230) | 240 (325) |
| 1-1/8 | 3/4 - 10 UNC | 144 (195) | 266 (360) | 376 (509) |
| 1-1/8 | 3/4 - 16 UNF | 192 (260) | 297 (402) | 420 (569) |
| 1-5/16 | 7/8 - 9 UNC | 166 (225) | 430 (583) | 606 (821) |
| 1-5/16 | 7/8 - 14 UNF | 184 (249) | 474 (642) | 668 (905) |
| 1-1/2 | 1 - 8 UNC | 250 (339) | 644 (873) | 909 (1232) |
| 1-1/2 | 1 - 12 UNF | 274 (371) | 705 (955) | 995 (1348) |
| 1-1/2 | 1 - 14 UNF | 280 (379) | 721 (977) | 1019 (1381) |
| 1-11/16 | 1-1/8 - 7 UNC | 354 (480) | 795 (1077) | 1288(1745) |
| 1-11/16 | 1-1/8 - 12 UNF | 397 (538) | 890 (1206) | 1444 (1957) |
| 1-7/8 | 1-1/4 - 7 UNC | 500 (678) | 1120 (1518) | 1817 (2462) |
| 1-7/8 | 1-1/4 - 12 UNF | 553 (749) | 1241 (1682) | 2013 (2728) |
| 2-1/16 | 1-3/8 - 6 UNC | 655 (887) | 1470 (1992) | 2382 (3228) |
| 2-1/16 | 1-3/8 - 12 UNF | 746 (1011) | 1672 (2266) | 2712 (3675) |
| 2-1/4 | 1-1/2 - 6 UNC | 870 (1179) | 1950 (2642) | 3161 (4283) |
| 2-1/4 | 1-1/2 - 12 UNF | 979 (1327) | 2194 (2973) | 3557 (4820) |

METRIC

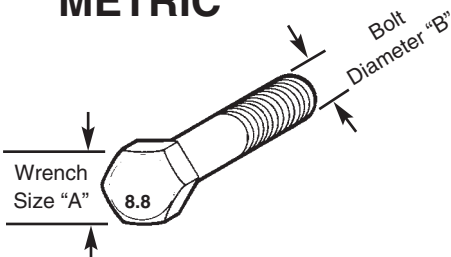

Numbers appearing on bolt heads indicate ASTM class.

Proper torque for metric fasteners used on Bush Hog equipment.
Recommended torque in foot pounds (newton Meters).*

| —WRENCH SIZE (mm) "A" | BOLT DIA. (mm) "B" | ASTM 4.6 | ASTM 8.8 | ASTM 9.8 | ASTM 10.9 |
|-----------------------|--------------------|-----------|-------------|-----------|-------------|
| 8 | 5 | 1.8 (2.4) | | 5.1 (6.9) | 6.5 (8.8) |
| 10 | 6 | 3 (4) | | 8.7 (12) | 11.1 (15) |
| 13 | 8 | 7.3 (10) | | 21.1 (29) | 27 (37) |
| 16 | 10 | 14.5 (20) | | 42 (57) | 53 (72) |
| 18 | 12 | 25 (34) | 74 (100) | 73 (99) | 93 (126) |
| 21 | 14 | 40 (54) | 118 (160) | 116 (157) | 148 (201) |
| 24 | 16 | 62 (84) | 167 (226) | 181 (245) | 230 (312) |
| 30 | 20 | 122 (165) | 325 (440) | | 449 (608) |
| 33 | 22 | | 443 (600) | | 611 (828) |
| 36 | 24 | 211 (286) | 563 (763) | | 778 (1054) |
| 41 | 27 | | 821 (1112) | | 1138 (1542) |
| 46 | 30 | 418 (566) | 1119 (1516) | | 1547 (2096) |

*Use 75% of the specified torque value for plated fasteners. Use 85% of the specified torque values for lubricated fasteners.

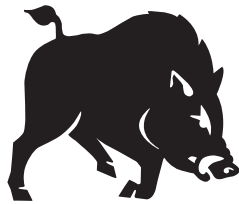

BUSH HOG[®]
Performance You Can Count OnSM

P.O. Box 1039 • Selma, AL 36702-1039
Telephone (334) 874-2700 • www.bushhog.com