

Operating instructions and spare parts list Harrow 6,00m





Thomas Hatzenbichler Agro-Technik GmbH

Fischering 2, A-9433 St. Andrä

Tel.: +43 4358 / 2287 - Fax: +43 4358 / 2208

e-mail: agrotechnik@hatzenbichler.com

Thomas Hatzenbichler Agro-Technik GmbH

Fischering 2, A-9433 St. Andrä
Tel.: +43 4358 / 2287 - Fax: +43 4358 / 2208
e-mail: agrotechnik@hatzenbichler.com



Acknowledgement of receipt

The acknowledgement of receipt must be returned immediately upon receipt. Without return there is **no** entitlement to a warranty!

*** Mandatory field**

Maschine type: **Harrow** *
Work width: **6,00 m** *
Serial number: *
Construction year: *

Additional equipment:
*
*
*

Customer

Customer no.: *
Company / Name: *
Name contact person: *
First name of the contact person: *
Street: *
ZIP: *
Place: *
Country: *
Tel.: *
Fax: *
E-mail: *

sold by

Customer no.: *
Company / Name: *
Name contact person: *
First name of the contact person: *
Street: *
ZIP: *
Place: *
Country: *
Tel.: *
Fax: *
E-mail: *

- » I hereby confirm the receipt of the operating instructions and spare parts list for the specified machine.
- » I am aware that the warranty claim will only become effective if this acknowledgement of receipt is completed in full and signed upon receipt and returned to the company Thomas Hatzenbichler Agro-Technik GmbH.
- » » by mail to: Thomas Hatzenbichler Agro-Technik GmbH, Fischering 2, A-9433 St. Andrä
- » » by fax to: +43 4358 / 2208
- » » by mail to: garantie@hatzenbichler.com

Place, date

Signature customer

Signature of dealer or
Hatzenbichler employee



Thomas Hatzenbichler Agro-Technik GmbH

Fischering 2, A-9433 St. Andrä

Tel.: +43 4358 / 2287 - Fax: +43 4358 / 2208

e-mail: agrotechnik@hatzenbichler.com

Table of contents		10	The little 1x1 of harrowing	20
1	Declaration of Conformity	2	11	Reaching the right stage of growth
2	Introduction	3	12	Adjustment options of the tine aggressiveness
2.1	Preamble	3		21
2.2	Representations	3		
2.3	Warranty and service	4	13	Assembly of the heel harrow field beams
2.4	Consequential damage	4		22
3	Safety	5	14	Spare parts list
3.1	Intended use	5		24
3.2	Personnel	5	15	Spare parts list - additional equipment
3.3	Maintenance work	5		32
3.4	Operational safety	5		
3.5	Accidents prevention	6		
3.6	Hydraulic system	6		
3.7	Transportation on public roads (main provisions)	6		
3.8	Safety sticker	7		
4	Commissioning	9		
4.1	Preparations on the tractor	9		
4.2	Hitching up the machine:	9		
5	Technical data	9		
5.1	Dimensions	10		
5.2	Transport position	10		
5.3	Axle load calculation	11		
5.4	Table for the ballast calculation	12		
6	Care and maintenance	12		
6.1	Machine lubrication	13		
6.2	Machine maintenance	14		
6.3	Tightening torques	15		
7	Structure of the harrow	16		
8	Mode of operation of the Hatzenbichler harrow	17		
9	Tips for using the harrow with different crops	18		
9.1	Winter cereals:	18		
9.2	Summer cereals:	18		
9.3	Maize:	18		
9.4	Turnip:	18		
9.5	Rape:	18		
9.6	Soy:	18		
9.7	Field Bean:	19		
9.8	Pea:	19		
9.9	Potato:	19		
9.10	Vegetables:	19		
9.11	Grassland and pasture farms:	19		

1 Declaration of Conformity



The manufacturer: **Thomas Hatzenbichler Agro-Technik GmbH**
Fischering 2,
A-9433 St. Andrä
Tel.: +43 4358 / 2287

hereby declares that the following product:

Product designation: **Harrow**

Work width: **6,00 m**

Serial number: _____

Construction year: _____

complies with all relevant provisions of the -Machinery Directive (2006/42/EC)
-Supply of Machinery (Safety) Regulations 2008

For the proper implementation of the safety and health requirements specified in the EC Directives the following standards and/or specifications have been applied.

DIN EN ISO 4254-1	Agricultural machinery - Safety - Part 1: General requirements
DIN EN ISO 12100	Safety of machinery - General principles for design - Risk assessment and risk reduction
DIN EN 60204-1	Safety of machinery - Electrical equipment of machines, Part 1: General requirements



Fischering, 22.11.2023
Place, date

Thomas Hatzenbichler
(manager)

2 Introduction

2.1 Preamble

Dear customer!

We are pleased and congratulate you on your purchase decision and wish you much fun and success in working with this device.

Read the operating instructions carefully before commissioning the machine. You will be informed about the handling, care and maintenance of the machine and reduce downtime and possible repair costs by paying attention.

All persons who operate, maintain, repair or transport this machine must have read and understood the operating instructions. Failure to observe the operating instructions will result in the loss of the warranty claim.

Hatzenbichler is not liable for damage or failure of the machine caused by non-observance of the operating instructions.

To ensure a safe and long operation of your machine, use only original spare parts from Hatzenbichler. The use of non-original spare parts will void the warranty or guarantee.

Any modification to the machine that has not been approved in writing by Hatzenbichler shall invalidate the warranty.

Hatzenbichler recommends the use of original spare parts even after the warranty period has expired in order to ensure the safe and reliable operation of your machine.

The illustrations in these instructions may differ from your machine, as additional equipment may also be installed in the illustrations.

All technical and design changes that serve to improve the machine are reserved.

In order to prove that you have received the machine and the operating instructions, it is necessary to return the acknowledgement of receipt enclosed in these instructions to Hatzenbichler immediately.

Hatzenbichler wishes you a lot of success.

2.2 Representations

The following representations are used in the operating instructions.

DANGER

This symbol, in the text section highlighted in gray, indicates a danger that can lead to fatal or serious injury if the instructions are not followed!

CAUTION

This symbol, in the text section with a gray background, indicates a danger that can lead to injury if the instructions are not followed!

INDICATION

This symbol indicates a note in the text section with a gray background.

The machine is intended for normal use in the agricultural sector. Any other use or use that goes beyond this is considered improper use.

Hatzenbichler is not liable for any damage resulting from this. The risk is borne solely by the user.

2.3 Warranty and service

Please check the machine for any transport damage immediately upon acceptance. Later claims resulting from transport damage can no longer be accepted.

We provide a one-year factory warranty from the date of delivery (your invoice or the delivery bill and the acknowledgement of receipt are considered the warranty certificate). This warranty applies in the event of defects in material or design and does not cover parts damaged by normal or excessive wear.

The warranty expires

- » if damage is caused by external force
- » if there is an operating error
- » if the prescribed KW/PS limitation is exceeded
- » if the device is modified, extended or fitted with third-party spare parts without our consent

The Hatzenbichler company wishes you to be satisfied with our machine, however, if you have any problems, please contact your distributor.

In order to process your request as quickly as possible, please provide us with the following information.

- » Customer number
- » Name and address
- » Name of the account manager
- » Machine type and serial number
- » Purchase date and area performance
- » Type of the problem

2.4 Consequential damage

Our machines are manufactured with the utmost care, but problems can still occur even if they are used as intended, which can lead to total failure of the machine under certain circumstances.

such as:

- » Damage to the machine due to external influence
- » worn out working tools
- » damaged or missing working tools
- » a wrongly adjusted machine
- » unsuitable working speed
- » lack of care and maintenance of the machine

Therefore, before each use of the machine, you should always check it for completeness and correct operation. Check this also during operation.

There is no entitlement to compensation for damage that has not occurred to the machine. This also includes that due to incorrect operation or driving errors, no liability is assumed for any resulting damage.

3 Safety

Before starting up or working on the machine, read these instructions carefully and observe all safety instructions.

3.1 Intended use

The machine is intended for common use for mechanical weed control in arable farming and grassland.

Any other use of this machine is considered improper. The Hatzenbichler company is not liable for any resulting damage. The operator alone is liable for risks arising from such improper use.

Intended use also includes observing the operating instructions and complying with the operating, maintenance and servicing instructions specified by the manufacturer.

3.2 Personnel

The machine may only be used, maintained and repaired by persons who are familiar with it, have been informed about possible dangers and meet the following minimum requirements:

- » She/he must be physically and mentally able to control the machine
- » She/he must have read and understood the operating instructions and be able to implement the information accordingly.
- » Repair work may only be carried out by authorized specialist personnel.

3.3 Maintenance work

The operating instructions describe maintenance work that the operator of the machine may perform independently. Activities that have not been described may only be carried out by authorized specialist personnel.

3.4 Operational safety

Illustrations as well as information on technical data and weights in these operating instructions are subject to change for the purpose of improvement.

The machine has been built according to the state of the art and according to the valid safety technical rules. Nevertheless, during use, risk of injury to the user or third parties may occur.

- » The machine may only be used in a technically perfect condition and in accordance with its intended use, in a safety-conscious and hazard-conscious manner and in compliance with the operating instructions!
- » Malfunctions that may affect safety must be eliminated immediately.
- » The installation or modification of non-Hatzenbichler products can negatively affect the design properties of the machine and thus impair the safety of man and machine.
- » If safety is no longer ensured due to defects, these must be rectified immediately.
- » Spare parts that do not originate from Hatzenbichler have not been tested or approved. If spare parts from other manufacturers are used, this may under certain circumstances change the design properties of the machine and influence the safety of man and machine. Hatzenbichler does not take any liability for any resulting damage.
- » Safety stickers on the spare parts to be replaced must be replaced in any case.



DANGER

Persons/parts of the body can be caught or crushed on hydraulically or mechanically driven machine parts.

- » The machine may only be put into operation if all required protective devices are attached and undamaged.
- » During the operation or folding process no person must be present in the vicinity of the machine.
- » Riding on the machine is strictly prohibited.
- » Maintenance or servicing work may only be carried out when the machine is at a standstill and in compliance with all safety regulations.

3.5 Accidents prevention

To ensure a safe and accident-free work on and with the machine, it is essential to observe the following section.

DANGER

The general accident prevention regulations of the respective country must be observed.

- » There is a risk of injury when coupling and uncoupling the machine to and from the towing device of the tractor.
- » When parking the device, it is essential to secure it against rolling away unintentionally
- » The device may only be used by persons who know the regulations for transport on public roads.
- » Place the hitched machine on the ground before

3.6 Hydraulic system

Every hydraulic system is under high pressure, thus leaking fluid can cause serious injuries.

CAUTION

Observe the following points to avoid injuries.

- » Do not connect the hydraulic hoses to the tractor until the hydraulics are depressurized on the tractor and implement sides.
- » Hydraulic hoses must be checked regularly and replaced immediately if damaged or aged. The hoses must be replaced after six years at the latest. Replacement lines must comply with the technical requirements.
- » Before carrying out any work on the hydraulic system, the implement must be set down, the hydraulic system depressurized and all hydraulic connections to the tractor disconnected.

3.7 Transportation on public roads (main provisions)

Before using public roads, you must be familiar with the operation of the machine and all controls.

When transporting on public roads, close the shut-off valve on the cylinders to prevent unintentional folding of the machine.

The axle load and the total weight of the tractor must not be exceeded.

The attachment must be marked with warning signs or foils with a white-red diagonal bar (according to DIN, ÖNORM, or respective standards).

Parts that are hazardous to traffic or dangerous must be covered and additionally marked with warning signs or foils.

Warning signs or foils should not be more than 1.50 m above the roadway when the vehicle is in motion.

Lighting devices of the tractor must not be covered by the implement, otherwise they must be repeatedly attached to the implement.

The steering ability of the tractor must not be impaired or reduced by the attachment.

The device may only be used by persons who know the regulations for transport on public roads.

When transported on public roads, it is allowed to drive with max. 25 km/h.

The permissible transport widths and heights must be observed. Pay attention to the transport height, especially for power lines and bridges.

INDICATION

When driving on public roads, appropriate traffic equipment is mandatory.

- » Observe the country-specific regulations

3.8 Safety sticker

These stickers warn of danger points and are an important part of the machine. Missing or damaged safety stickers must be replaced immediately.

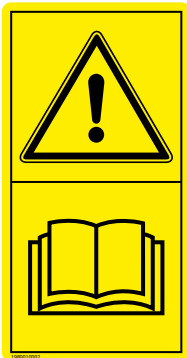

1980010002

Before commissioning the machine, read and follow the operating instructions!



1980010004

Riding on the machine is prohibited!



1980010005

When hitching up the machine and operating the hydraulics, make sure that there are no persons between the machines!



1980010006

Never reach into the crushing hazard area as long as parts can move there!



1980010003

Do not stay within the swiveling range of foldable machine parts!



1980010001

Caution with escaping high-pressure liquid!

Bei Straßentransport Ventil schließen! (D)
For road transport close valve! (GB)
Fermer le robinet pendant le transport! (F)
В транспортном положении – закрыть! (RU)

1980010007

In transport position, the valve on the cylinders must be closed!

Nach der erstmaligen Inbetriebnahme sind sämtliche Schraubverbindungen nachzuziehen! (D)
Retighten bolts and nuts after the first use of the machine! (GB)
Reserrez tous les boulons après les premières heures de travail! (F)
После начала эксплуатации необходимо сделать повторную протяжку всех болтовых соединений! (RU)

1980010008

After the first commissioning, all screw connections must be tightened!

! INDICATION

If safety stickers are damaged, they must be replaced.
 » You will find the article number of the sticker on the lower left corner of each safety sticker.

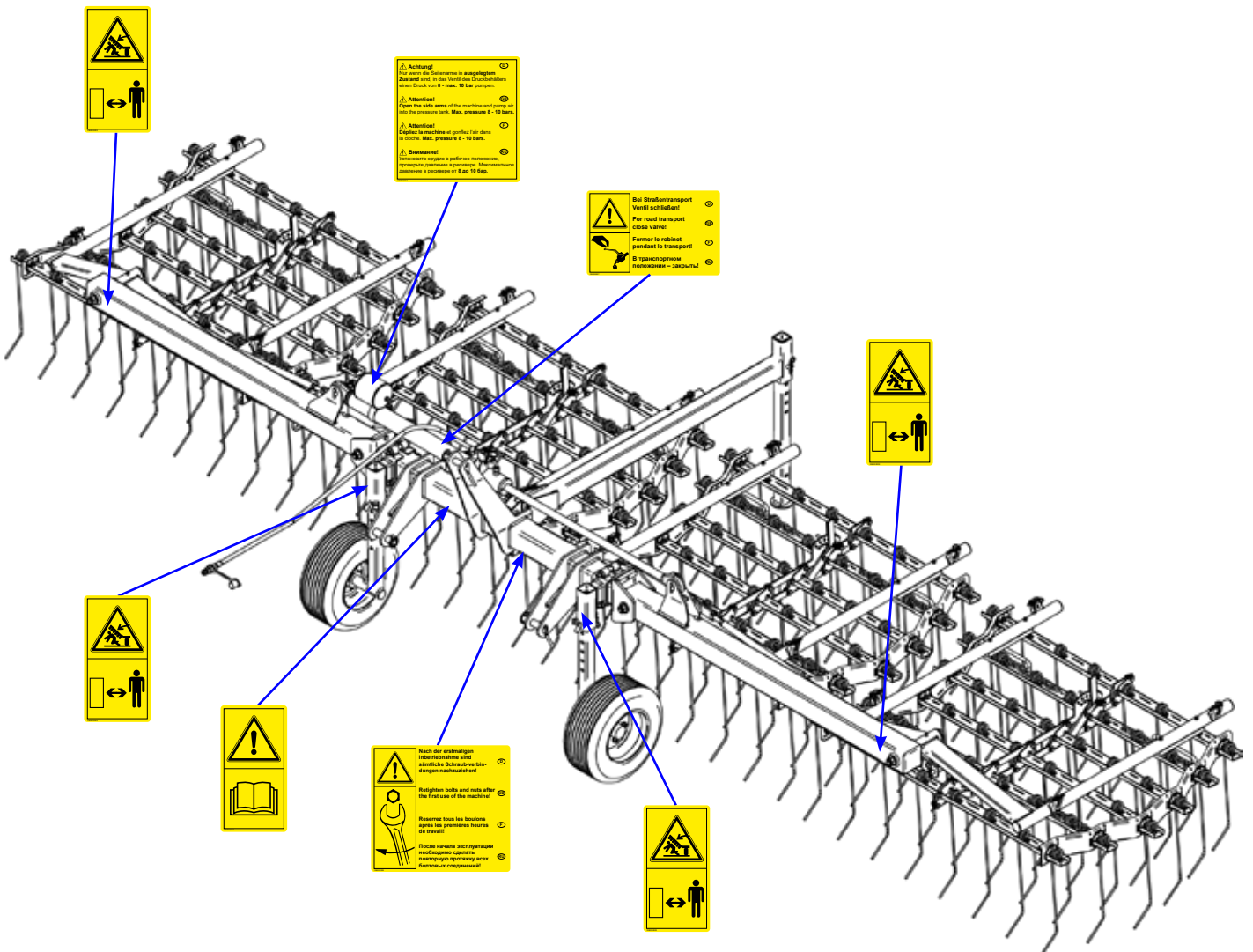

4 Commissioning

- » Pay attention to the correct air pressure in the tractor rear tires when operating.
- » Additional wheel weights can be advantageous under difficult operating conditions. Refer to the tractor manufacturer's operating instructions.

4.1 Preparations on the tractor

- » The tractor must be sufficiently ballasted at the front to ensure steering and braking ability.

INDICATION

Please refer to the section on axle load range in these operating instructions.

- » The lifting struts must be set at the same height on the left and right.

4.2 Hitching up the machine:

- » Hitch the machine to the three-point, drawbar or ball hitch on the tractor, depending on the equipment.
- » Connect the hydraulic lines. In case of double-acting hydraulic connections, make absolutely sure that both hoses are connected to the tractor hydraulics. When connecting, make sure that the hoses are depressurized on the tractor and machine sides.
- » Connect the plug for the lighting and check the function.
- » Lift the machine.
- » Remove or raise the parking support (if available)
- » Fold in (for transport) or fold out side panels for the working position.

INDICATION

During transport, observe the transport position section in these operating instructions.

5 Technical data

Work width	Weight	Number of fields	Required power	Transport height	Transport width
1,50m	ca. 200 kg	1 x 1,50m	ab 11kW (15PS)	1,20m	1,60m
2,00m	ca. 220 kg	1 x 2,00m	ab 11kW (15PS)	1,20m	2,15m
3,00m	ca. 300 kg	2 x 1,50m	ab 11kW (15PS)	1,20m	3,00m
4,50m	ca. 450 kg	3 x 1,50m	ab 11kW (15PS)	1,65m	2,85m
5,00m	ca. 470 kg	1 x 2,00m + 2 x 1,50m	ab 18kW (25 PS)	1,90m	2,85m
6,00m	ca. 550 kg	4 x 1,50m	ab 29kW (40 PS)	2,40m	3,00m
7,50m	ca. 790 kg	5 x 1,50m	ab 37kW (50 PS)	3,15m	3,00m
8,00m	ca. 810 kg	1 x 2,00m + 4 x 1,50m	ab 37kW (50 PS)	3,40m	3,00m
9,00m	ca. 910 kg	6 x 1,50m	ab 44kW (60 PS)	3,90m	3,00m
9,00m*	ca. 1140 kg	6 x 1,50m	ab 44kW (60 PS)	2,75m	3,00m
10,50m*	ca. 1300 kg	7 x 1,50m	ab 48kW (65 PS)	3,55m	2,75m
12,00m*	ca. 1410 kg	8 x 1,50m	ab 51kW (70 PS)	3,55m	3,00m
13,50m*	ca. 1560 kg	9 x 1,50m	ab 55kW (75 PS)	4,30m	2,75m
15,00m*	ca. 2100 kg	10 x 1,50m	ab 59kW (80 PS)	4,30m	3,00m

Tines: Ø6mm - l=380mm; Ø7mm - l=410mm u. l=450mm; Ø8mm - l=410mm u. l=450mm;

* Shear flap version

5.1 Dimensions

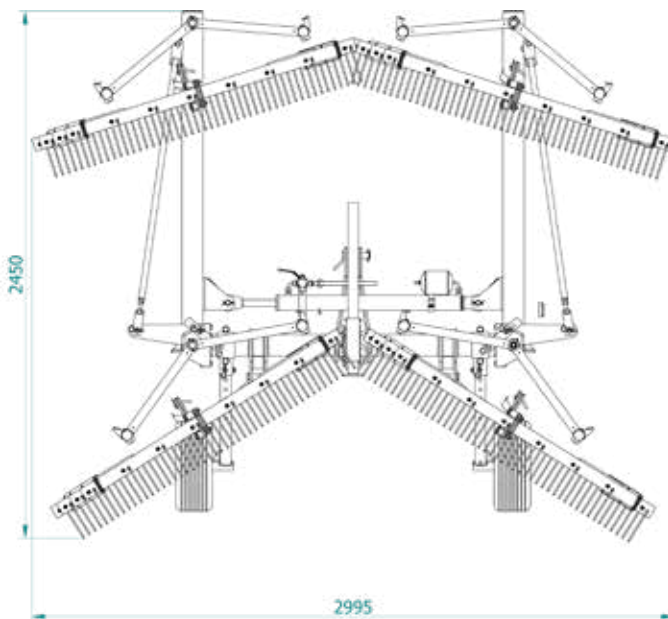
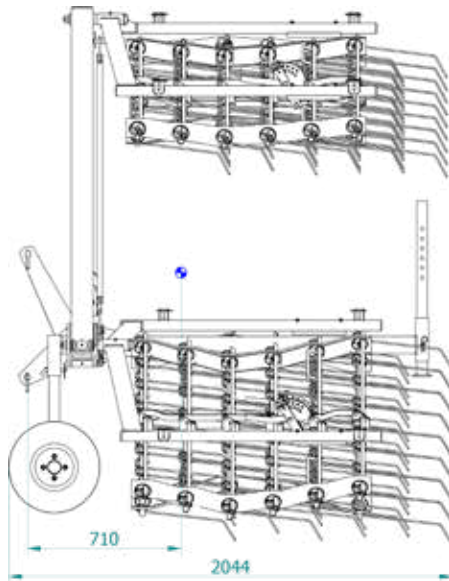

5.2 Transport position

Before folding the machine, the harrow fields must be set to the flattest setting. If this is not observed, it cannot be ruled out that the harrow tines will get caught.

! INDICATION

When driving on public roads, the permissible transport widths and heights must be observed.

- » To ensure that the transport width can be maintained, the fixing flat irons of the harrow sections must be hooked into the 2nd slotted hole on the middle section (as marked with detail A in the illustration).

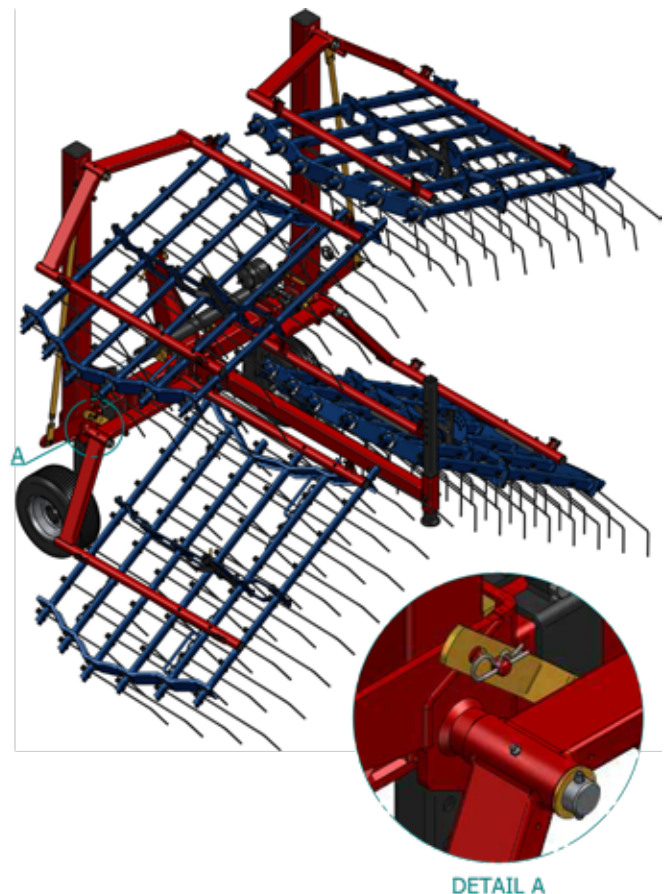

5.3 Axle load calculation

By hitching a machine in 3-point, this changes the total weight and axle loads of the towing machine. These values must not exceed the permissible weight. The front axle of the tractor must always be loaded with 20% of the own weight.

CAUTION

Before road transport, check that the tractor is not overloaded and that the permissible weights are not exceeded.

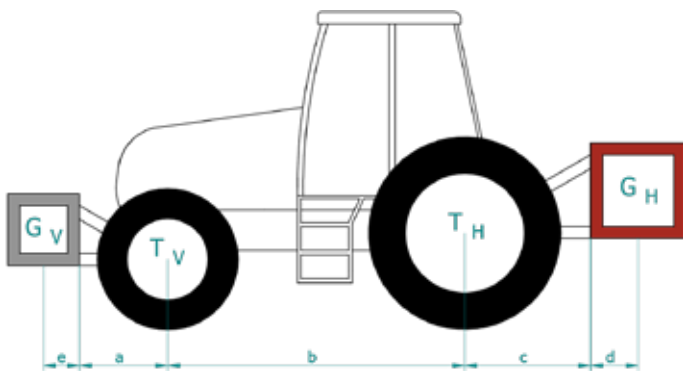

- T_L Tractor own weight
- T_V Front axle load of the empty tractor
- T_H Rear axle load of the empty tractor
- G_H Total weight rear attachment
- G_V Total weight front attachment
- a Distance from center of lower link ball to center of front axle
- b Tractor wheelbase
- c Distance from center of rear axle to center of lower link ball
- d Distance from center of lower link ball to center of gravity
- e Distance from center of gravity front attachment (front ballast) to center of lower link ball

all weights in kg and dimensions in mm

INDICATION

For the dimension of the center of gravity, see chapter „Technical data - Dimensions“

Calculation of minimum ballasting front for rear mounted implements

$$G_{V\text{mind}} := \frac{G_H \cdot (c + d) - T_V \cdot b + 0.2 \cdot T_L \cdot b}{a + e + b}$$

Enter the result in the table below.

Calculation of the minimum rear ballasting for front mounted implements

$$G_{H\text{mind}} := \frac{G_V \cdot (a + e) - T_H \cdot b + 0.45 \cdot T_L \cdot b}{b + c + d}$$

Enter the result in the table below.

Calculation of the actual front axle load

$$T_{V\text{tat}} := \frac{G_V \cdot (a + e + b) + T_V \cdot b - G_H \cdot (c + d)}{b}$$

Enter the result and the permissible front axle load from the operating manual for the tractor in the table below.

Calculation of the actual total weight

$$G_{\text{tat}} := G_V + T_L + G_H$$

Enter the result and the permissible total weight from the operating manual for the tractor in the table below.

Calculation of the actual rear axle load

$$T_{H\text{tat}} := G_{\text{tat}} - T_{V\text{tat}}$$

Enter the result and the permissible rear axle load from the operating manual for the tractor in the table below.

Enter the value of the permissible tire load capacity from the tire manufacturer's documentation in the table. Be sure to multiply the value by the number of wheels mounted per axle.

In addition, check the calculated values by weighing.

5.4 Table for the ballast calculation

	actual value according to calculation		permissible value according to operation manual		permissible tire load capacity per axle
Minimum front ballast for rear mounted implements	$G_{Vmind} =$ kg				
Minimum rear ballast for front mounted implements	$G_{Hmind} =$ kg				
Total weight	$G_{tat} =$ kg	≤	kg		
Front axle load	$T_{Vtat} =$ kg	≤	kg	≤	kg
Rear axle load	$T_{Htat} =$ kg	≤	kg	≤	kg

6 Care and maintenance

- For maintenance and servicing work, park the machine on level and stable ground and secure it against rolling away.

- After cleaning, check all hydraulic lines for leaks and loose connections. (check the hydraulic connections and hoses approx. every 50 operating hours).

- Inspect for chafing and damage. Immediately correct any defects found.

- Check nuts and bolts regularly for tightness and retighten if necessary. (For new devices, after 10 operating hours at the latest and again after approx. 20 operating hours.)

- Do not use a high-pressure cleaner to clean bearing and hydraulic parts.

- During the winter, protect the device from rust with environmentally friendly agents.

- Park the unit protected from the weather and store it in such a way that no unnecessary pressure is exerted on the working tools of the machine.

INDICATION

Hydraulic cylinders, bearings as well as electrical components should never be cleaned with high pressure or direct water jets.

» non-observance can lead to damage of the parts

6.1 Machine lubrication

Lubricate the machine regularly and after each wash.

Lubrication points - grease: DIN 51825 - K2K-30

Pos. no:	Designation	Number of lubrication points on the machine	Interval
1	Heel harrow field beam	4x	50 h
2	Side arm (left and right side)	2x	50 h

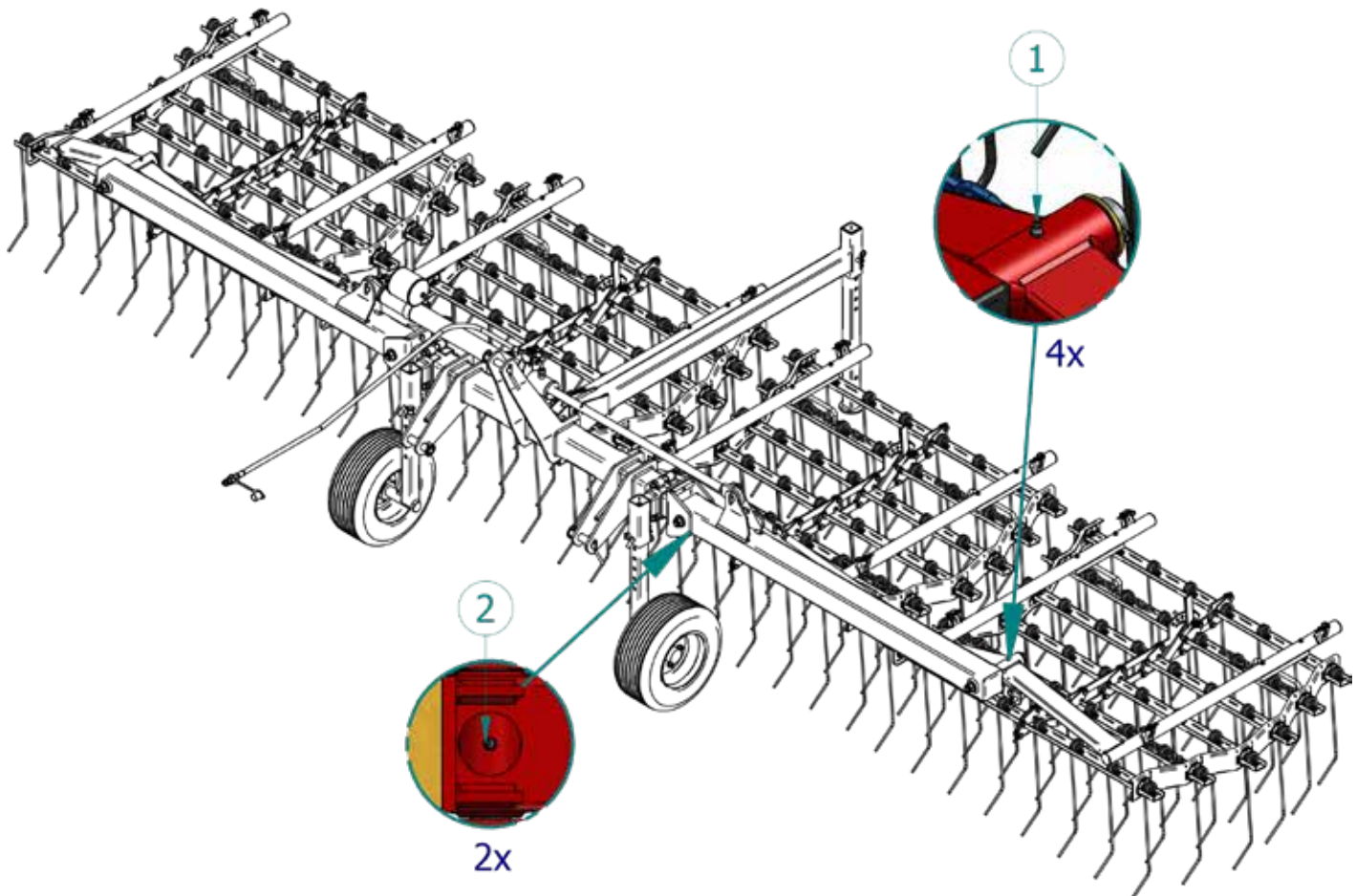

6.2 Machine maintenance

Since the maintenance intervals of the machine can be influenced by many factors (operating conditions, operating speed, travel speed, quality of the lubricants used...), the following intervals only serve as reference values and must be adjusted accordingly if required.

Designation	Remarks	Interval
Screw connections	After the first 10 and 20 hours of operation, check all screw connections for tightness. After that, stick to the interval.	weekly
Wheel nuts M12x1,5 (90 Nm $^{+10}_{-0}$)	<ul style="list-style-type: none"> » after the first use or 10 hours » again after another 10 hours » tighten daily until further tightening is no longer possible » acc. to the interval 	50 h

Hydraulic system



CAUTION

Before working on the hydraulic system, make sure that the machine is parked on solid ground and that the hydraulic system is depressurized.

» after operating the machine, allow the hydraulic system to cool down

Hydraulic connections	After the first 10 hours of operation, check all hydraulic connections, then according to the interval.	weekly
Hydraulic hoses	<ul style="list-style-type: none"> » Check hydraulic hoses for cracks, chafe marks » damaged hoses must be replaced immediately » after 6 years at the latest, the hydraulic hoses must be replaced. The date of manufacture can be found on the hydraulic hose (quarter/year). <div style="text-align: center; margin: 10px 0;">  </div> <ul style="list-style-type: none"> » depending on operating conditions and weather, an earlier change may also be necessary 	50 h

Wheels

Wheels	Checking the wheels for damage	daily
	Check air pressure » 16x650: 3,5 bar	daily

Safety devices

Warning signs and lighting	Check function and condition	daily
Safety and warning stickers	Check legibility and presence	daily

6.3 Tightening torques

INDICATION

Nuts and bolts must not be treated with oils or lubricants, as this affects the coefficient of friction.

The following torques are guide values for new screws without oil or lubricant.

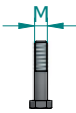
metric screws - standard thread		
	Tightening values in Nm for strength classes	
	8.8	10.9
M4	3,0	4,3
M5	6,0	8,5
M6	10,3	14,7
M8	25,5	35,3
M10	50,0	70,6
M12	87,3	122,6
M14	138,3	194,2

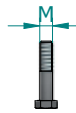
metric screws - standard thread		
	Tightening values in Nm for strength classes	
	8.8	10.9
M16	210,8	299,1
M18	289,3	411,9
M20	411,9	578,6
M22	559,0	784,5
M24	711,0	1000,0
M27	1049,0	1481,0
M30	1422,0	2010,0

7 Structure of the harrow

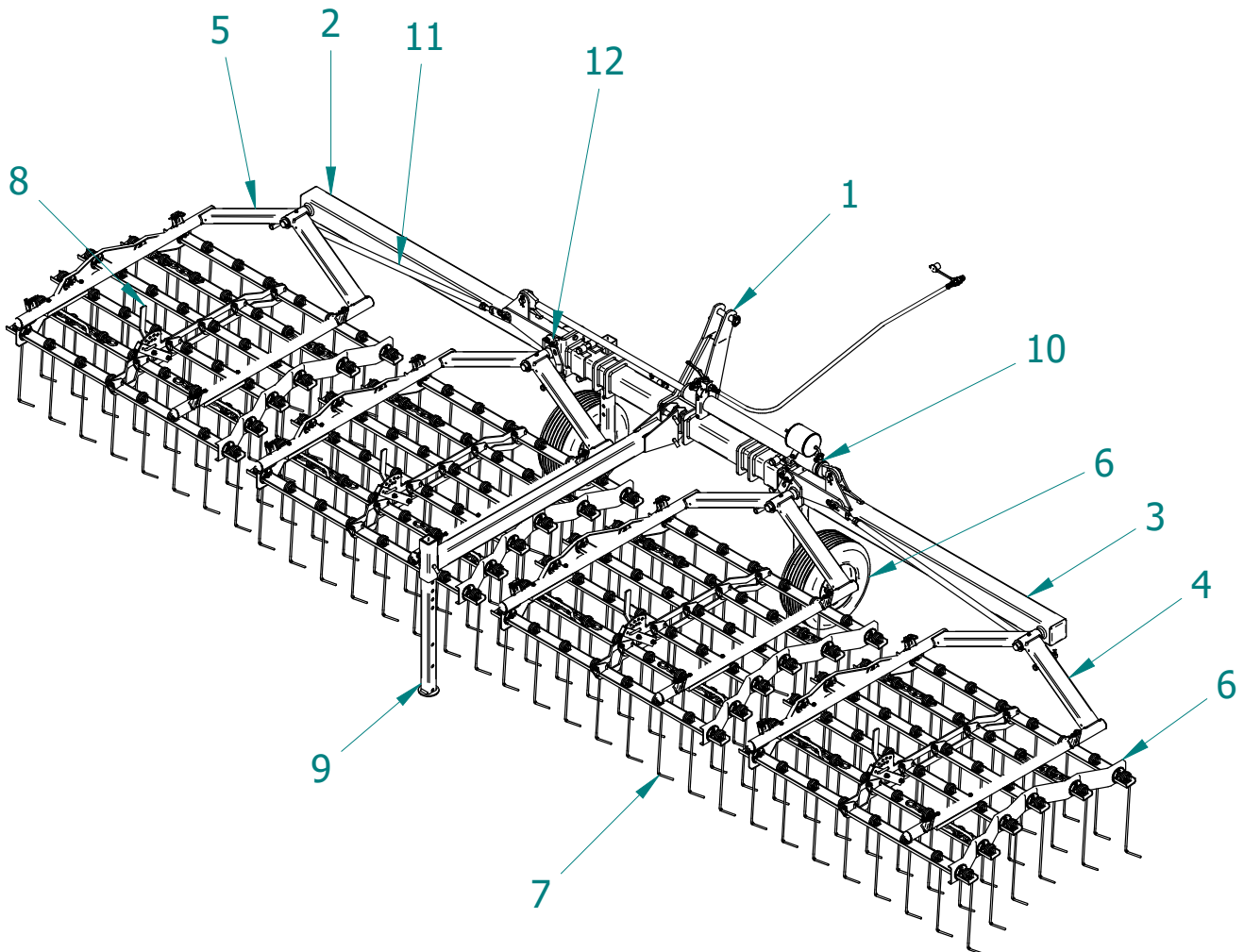

1. 3-point hitch harrow
2. Side arm left
3. Side arm right
4. Heel harrow field beam right
5. Heel harrow field beam left
6. Harrow Field

7. Harrow tine
8. Adjustment lever for tine adjustment
9. Parking support
10. Hydraulic cylinder
11. Retractable linkage
12. Fixing flat iron

8 Mode of operation of the Hatzenbichler harrow

The Hatzenbichler harrow has been used for mechanical weed control for more than 30 years in almost all soil crops, such as cereals, rapeseed, soybeans, beans, peas, maize, in grassland, etc.

The vibrating tines break up the soil crust and aerate the soil again.

The water balance is regulated and the soil fermentation is maintained.

By optimal adjustment of the tine pressure, which can also be done hydraulically with additional equipment, the Hatzenbichler harrow offers perfect working.

The tines are made of oil-hardened spring steel wire, making them very durable and robust. Due to the vibration of the spring tines in combination with the driving speed, a surface covering processing is achieved.

Due to the protected spring coil, a pinching off of the crop tips is prevented.

Six rows of tine bars are mounted on a spring toothed harrow field (10 adjustment possibilities - see

„Adjustment options for the tine aggressiveness“).

Each spring tooth harrow field is individually suspended on chains on the special tubular frame. This results in the best ground hugging and extremely smooth running of the entire machine. Hydraulic level compensation can also be fitted as an optional extra.

The support wheels are height adjustable.

The transport position of the harrow is hydraulic (Euro folding). Devices with shearing folding are equipped with 2 pieces of double-acting cylinders (you need two double-acting control units on the tractor).

9 Tips for using the harrow with different crops

9.1 Winter cereals:

Autumn

1. Work input

Blind harrowing (means harrowing before spiking the seed)

Effect:

- » Breaking the soil crust and ventilate
- » Destruction of the already germinating weeds

2. Work input

If sown early, easy to use at the 2- to 3-leaf stage.

Spring

3. Work input

as soon as the vegetation starts, medium setting

Effect:

- » Soil loosening
- » Stocking stimulation
- » Reinforcement of the culm

4. Work input

at 30-40cm growth height

Effect:

- » Late seedling control
- » Nutrient mobilization
- » Creation of balanced growth conditions

5. Work input

with Hatzenbichler inter row cultivator (if row crop)

9.2 Summer cereals:

1. Work input

blindweeding after sowing

2. Work input

harrow at 3-leaf stage, medium setting

3. Work input

at 30-40 cm height of growth

In spring barley, it is especially important to harrow as efficiently as possible when early stage, as heavier weed pressure occurs in the spring.

4. Work input

with Hatzenbichler interrow cultivator (if in row crop)

9.3 Maize:

1. Work input

Blind harrowing (before seed germination)

2. Work input

at 8-15 cm height of the plant

With plant height of 8 - 15 cm, the harrow can be used over the entire surface. Due to the exible tine tools, which avoid the static pressure of the corn plant, a weed control over the whole area is achieved. Harrowing is carried out at this stage of growth on warm days, when the corn plants are softer due to the warmth of the sun and therefore do not bend over.

3. Work input

with the Hatzenbichler corn chopper or roll star chopper

9.4 Turnip:

1. Work input

blind harrowing, gentle setting

2. Work input

3-4 cm plant height

3. Work input

should be done with a Hatzenbichler beet cultivator machine

9.5 Rape:

Autumn

1. Work input

at about 20 cm plant height, very careful setting

Effect:

- » Soil loosening
- » Improve nutrients availability
- » Destruction of autumn germination not yet visible

Spring

2. Work input

as soon as the vegetation starts, medium setting

Effect:

- » Soil loosening
- » Branching promotion

9.6 Soy:

1. Work input

blind harrowing, gentle setting

2. Work input

at 3-4 leaf stage, medium setting

3. Work input

depending on weed infestation, strong setting

4. Work input

just before the end of the row, work with a Hatzenbichler interrow cultivator

9.7 Field Bean:

1. Work input

blind harrowing, strong setting

2. Work input

at 8-leaf stage, medium setting

3. Work input

at 15-20cm plant height

Effekt:

- » Soil loosening before the row closure of the plants
- » optimal soil aeration until harvesting

4. Work input

with Hatzenbichler interrow cultivator machine

9.8 Pea:

1. Work input

blind harrowing, gentle setting

2. Work input

8-leaf stage

9.9 Potato:

1. Work input

blind currying, medium setting

2. Work input

3-4-leaf stage, then piling up with Hatzenbichler roller star hoe

9.10 Vegetables:

1. Work input

Seedlings - at growth height 4-5 cm, gentle setting

Seedlings - about 14 days after planting, gentle setting

2. Work input

depending on weeds and soil conditions

3. Work input

with the Hatzenbichler special vegetable interrow cultivator machine

9.11 Grassland and pasture farms:

Spring tooth hoe harrow used in conjunction with spreaders to level molehills, cow pies, grind manure, slurry and aerate turf. Uniform cultivation even on uneven ground, thanks to the adjustment of the moving field and the high passage forked tines - no clogging.

10 The little 1x1 of harrowing

The success of a Hatzenbichler harrow in weed control is achieved to 30% by burying weeds in the germination stage and only to about 70% by pulling out the weeds. From this fact, several conditions can be derived for a good success of the harrow application:

- The soil should be as cooked and pourable as possible. Therefore, especially on clay and silt-rich soils that tend to crust, the PH value in the top crumb layer must be correct. On critical (hourly) soils, for trowing in spring as well as for blind harrowing, relatively light implements with large working widths on the lightest possible tractors are suitable in order to minimize track damage. When trowing and blind harrowing, good ground hugging is essential. Devices with a movable design or with as many individual fields as possible that can be twisted into each other show the best results. Depending on the soil conditions, it is necessary to work with lower or higher zinc pressure.
- The seedbed of harrow areas must be coarsely tilled in the fall to still have bulkable soil in the spring.
- The faster the harrow is driven, the greater the impact and the control success.

11 Reaching the right stage of growth

Measures that take place before the crops emerge are particularly effective. Weed control must therefore be coordinated as closely as possible with the timing of soil cultivation and sowing.

- » Wherever possible, sowing and blind-row rowing should be preceded by the time-honored „trowing“ to encourage an entire generation of weeds in the top seedbed layer to germinate in time.
- » Blind harrowing (before the grain emerges) often produces very good results. It can be done until the top of the grain (stage EC 07 to EC 10).
- » It is at the germination or small leaf stage of weeds that the greatest control success (up to 80%) is achieved by burying or exposing.
- » The optimal time for weeding(weed germination through the seedbed) can be determined with the help of a window pane. When the first cotyledons appear, the harrow should be used.
- » In rye, winter barley and early-sown wheat in cereal-rich rotations, the fall germinators windstalk and foxtail often cause the most problems. In rye and winter barley, harrowing success depends on timely pre-winter application. For wheat, a slightly later seeding extends the harrow period and lowers weed pressure.
- » Once weeds are past the cotyledon stage and into the small rosette stage, control is more difficult: Here, weeding must be sharper (more tine pressure or steeper setting of the tines), because the weeds can hardly be pulled out and survive even spilling.
- » Especially effective is harrowing on sunny and windy days, later in the morning. Exposed weed seedlings then dry up already by the afternoon.

12 Adjustment options of the tine aggressiveness

The adjustment of the aggressiveness of the tines (angle of attack of the tines) is carried out according to the enclosed drawing by means of a central adjustment lever or hydraulically (option) via a hydraulic cylinder.

The hydraulic tine adjustment is carried out by means of hydraulic cylinders via a gearwheel flow divider, which ensures uniform distribution of the oil flow to all hydraulic cylinders and simultaneous control of the hydraulic tine adjustment from shallow to aggressive. A double-acting connection is required on the tractor side. In addition to the gearwheel flow divider, a locking block is mounted on each cylinder to prevent an unintentional change of position under load.

Mechanical tine adjustment is via an adjustment lever with 10 setting options from shallow to aggressive.

! INDICATION

For each harrow field, the bolt must be in the same hole at the adjusting device.

! INDICATION

After adjusting the hydraulic tine adjustment, briefly move the lever of the control unit to the floating position to relieve the valve.

Angle of attack of the tines

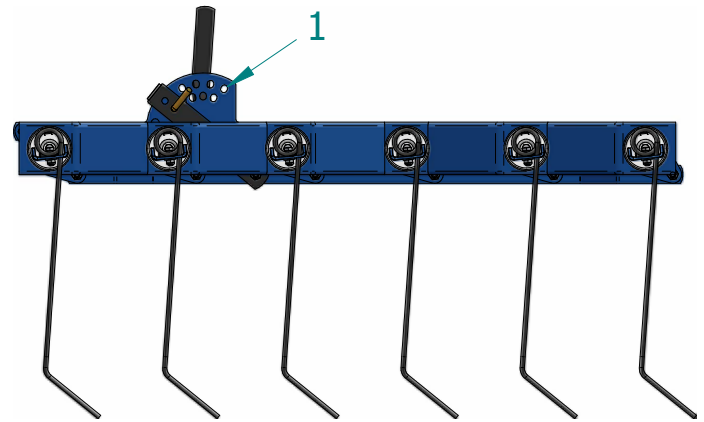

aggressive tine adjustment

1 - indicates the 10 adjustment possibilities of the tine field

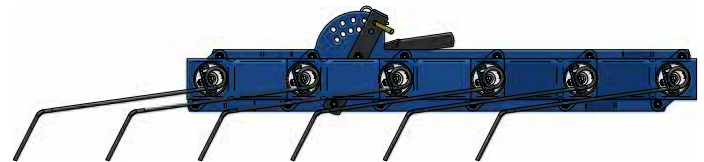

shallow tine adjustment

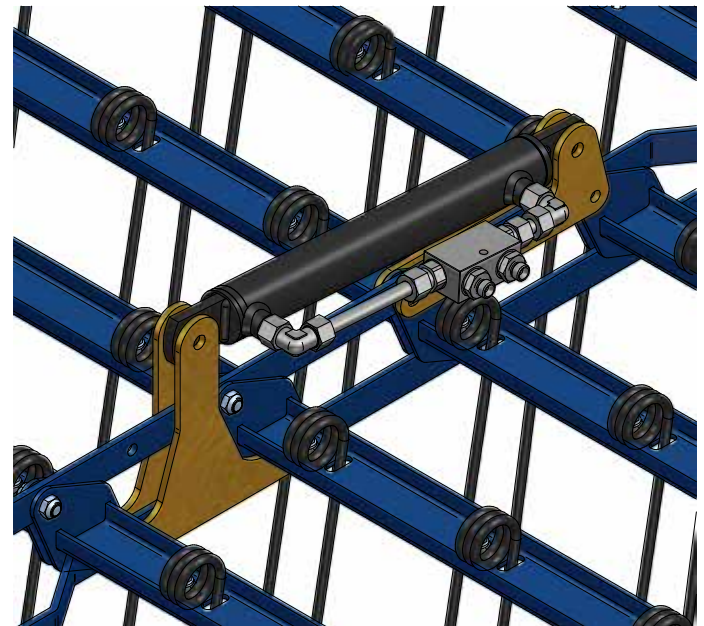

hydraulic tine adjustment (option)

13 Assembly of the heel harrow field beams

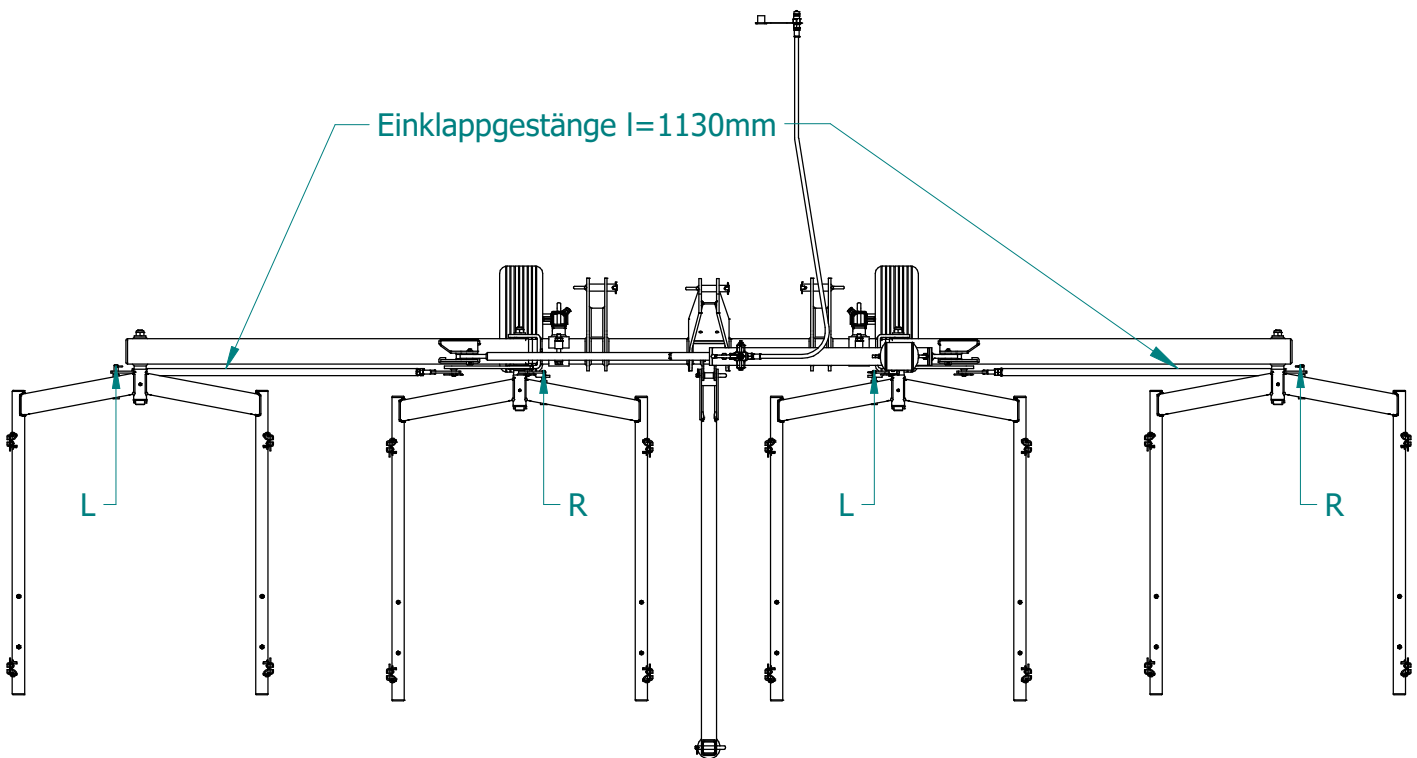

When assembling the heel harrow field beam, make sure that the left and right field beams are not mixed up.

- Heel harrow field beam left **(L)**
viewed in the direction of travel, the bolt is located on the left side of the heel harrow field beam

- Heel harrow field beam right **(R)**
viewed in the direction of travel, the bolt is located on the right side of the heel harrow field beam

However, if there is any confusion during assembly, it is not possible to mount the folding rods (on folding machines) or fixing lugs. The device may be damaged as a result.

Thomas Hatzenbichler Agro-Technik GmbH

Fischering 2, A-9433 St. Andrä

Tel.: +43 4358 / 2287 - Fax: +43 4358 / 2208

e-mail: agrotechnik@hatzenbichler.com



14 Spare parts list

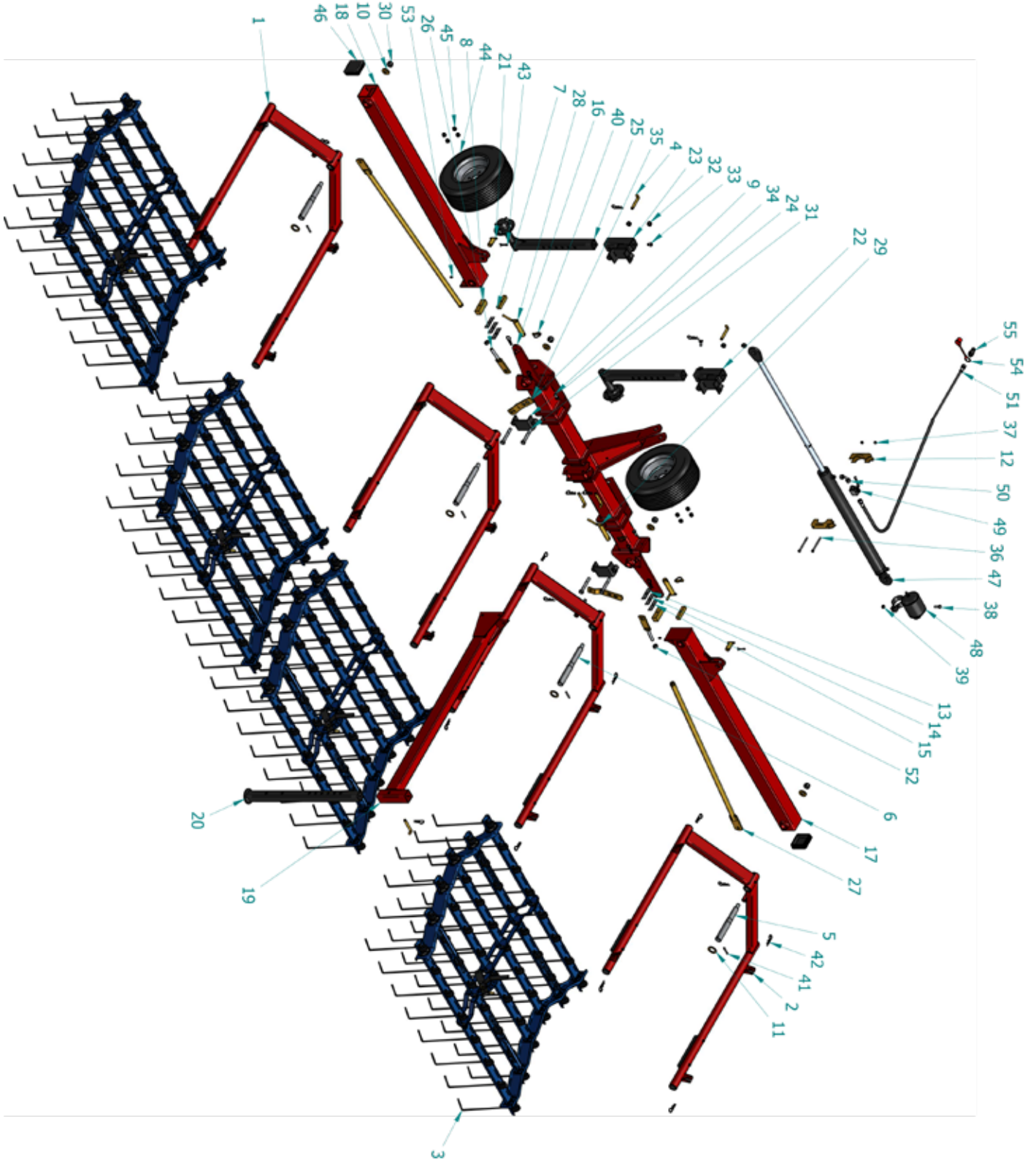

Thomas Hatzenbichler Agro-Technik GmbH

Fischering 2, A-9433 St. Andrä

Tel.: +43 4358 / 2287 - Fax: +43 4358 / 2208

e-mail: agrotechnik@hatzenbichler.com



Art.Nr.:	Pos.-Nr.	Bezeichnung	Menge
0104010001	1	HEFT with bolt left compl.	2
0104020001	2	HEFT with bolt right compl.	2
0110020001	3	Heel harrow field 1,50m compl. with 7mm chopping harrow tines	4
1903030008	4	Locking pin Ø14 - 130 mm	5
1903050002	5	Beam stub short; M20	2
1903050001	6	Beam stub long; M20	2
1999050002	7	Stop small f. harrow	2
1999050001	8	Stop large f. harrow	2
0108020001	9	Fixing flat iron	2
0199010102	10	Washer f. M20, AD=45	4
0199010103	11	Washer Ø52.5 f. beam stub	4
0199010119	12	Anti-twist f. 6m harrow	2
0199010163	13	Spacer plate 3mm f. joint harrow	2
0199010162	14	Spacer plate 1.5mm f. joint harrow	2
0199010161	15	Spacer plate 1mm f. joint harrow	2
0101040001	16	Middle part harrow 6,00m	1
0102050001	17	Side arm right f. 6m harrow	1
0103050001	18	Side arm left f. 6m harrow	1
0105030003	19	Parking support straight	1
0105030002	20	Parking support l=806	1
1903060001	21	Welding stud Ø25 - l=55mm	2
0105040002	22	Wheel holder front 40mm - f. wheel stem small left	1
0105040003	23	Wheel holder front 40mm - f. wheel stem small right	1
1913020004	24	Blind plate f. FR100x100 - black	2
0105040004	25	Wheel stem f. harrow	2
0108010007	26	Tab w. oblong hole f. folding linkage	2
0108010014	27	Folding linkage compl. l=1130mm	2
1903010002	28	UL bolt cat. 2	2
1903020002	29	OL bolt cat. 2	1
1902010001	30	Locking nut M20 - DIN 985	4
1901010078	31	Hexagon head screw DIN 931 M16x110	4
1902010014	32	Locking nut M16 - DIN 985	4
1901010005	33	Hexagon head screw DIN 933 M12x25	2
1901010035	34	Hexagon head screw DIN 933 M12x30	2
1901010011	35	Hexagon head screw DIN 933 M12x40	2
1901010077	36	Hexagon head screw DIN 931 M8x110	2
1902010002	37	Locking nut M8 - DIN 985	2
1901010012	38	Hexagon head screw DIN 933 M10x35	1
1902010005	39	Locking nut DIN 985 M10	1
1904010002	40	Hinged cotter pin large Ø10mm	3
1905010002	41	Dowel pin ISO 8752 - 8 x 50	4
1904020002	42	Spring cotter Ø4mm	29
1904010004	43	Splint ISO 1234 - 6,3 x 40	2

Art.Nr.:	Pos.-Nr.	Bezeichnung	Menge
1914030001	44	Wheel 16x6.50-8	2
1902030001	45	Wheel nut M12	8
1916010003	46	PVC plug 100x100	2
1912010016	47	Hydraulic cylinder f. FZHE 4,5m, 5m, 6m, 7,5m, 8m and 9m rigid	1
0116010012	48	Pressure pot f. 6 m harrow	1
1912060001	49	Stopcock 12L - 18x1,5	1
1912030003	50	WZ 12L - angular spigot	1
1912020036	51	Hydraulic hose DN8 straight-straight l=1500mm	1
1902020004	52	Hexagon nut DIN 934 - M16	2
1906060001	53	Conical grease nipple DIN 71412 - A M8x1	2
1912040001	54	Dust cap red	1
1912030001	55	12L Push Pull Plug	1

Thomas Hatzenbichler Agro-Technik GmbH

Fischering 2, A-9433 St. Andrä

Tel.: +43 4358 / 2287 - Fax: +43 4358 / 2208

e-mail: agrotechnik@hatzenbichler.com



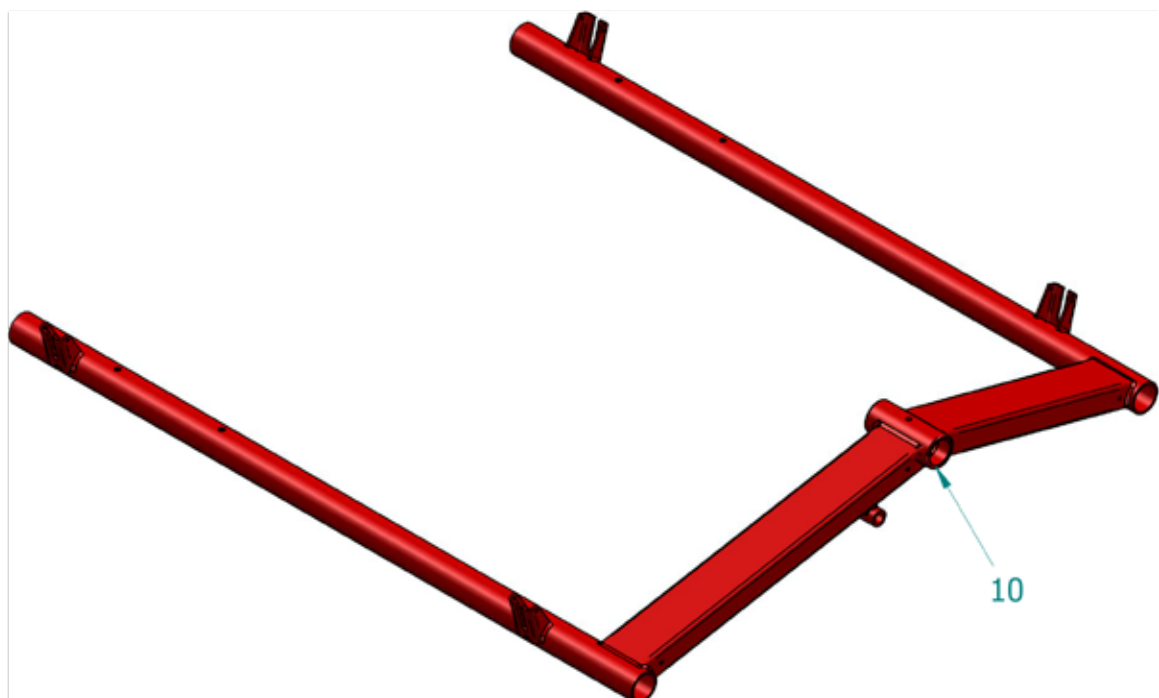
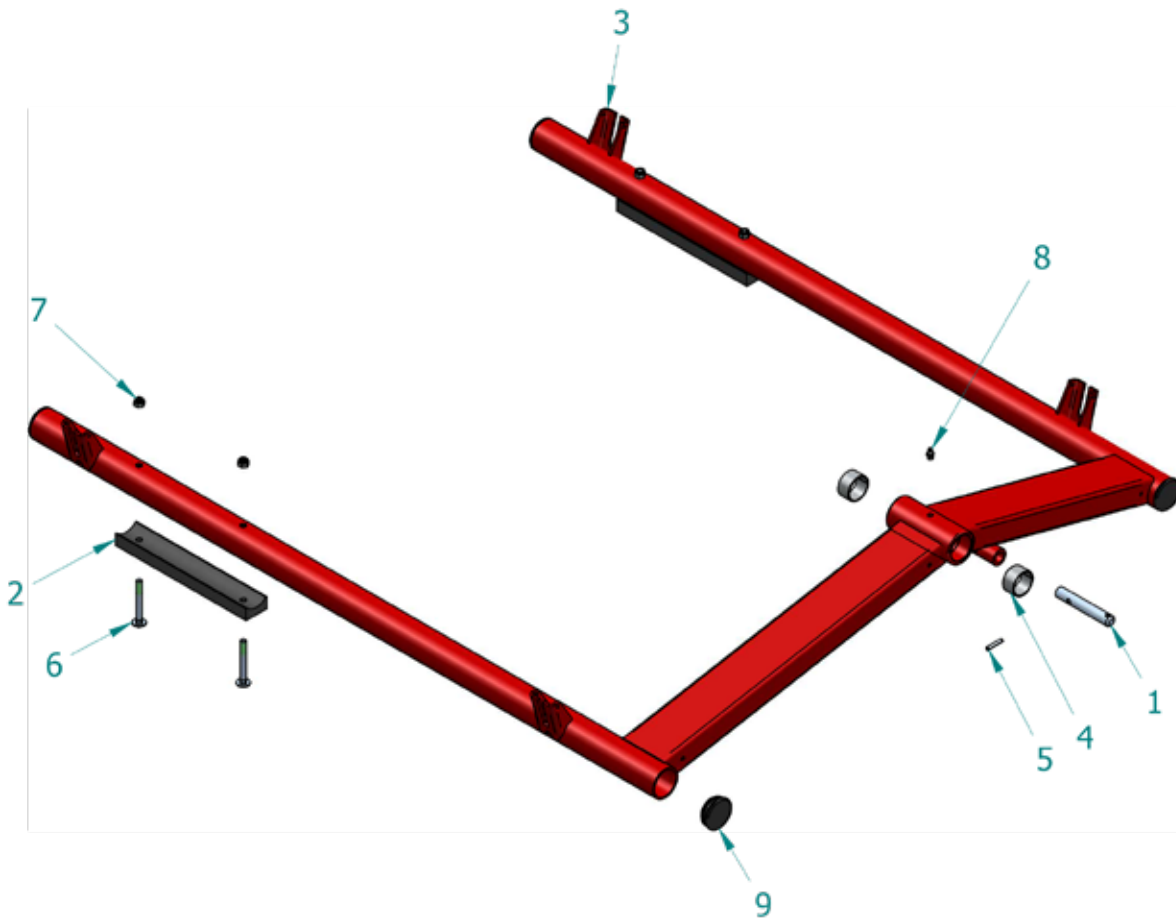

Thomas Hatzenbichler Agro-Technik GmbH

Fischering 2, A-9433 St. Andrä

Tel.: +43 4358 / 2287 - Fax: +43 4358 / 2208

e-mail: agrotechnik@hatzenbichler.com



Art.Nr.:	Pos.-Nr.	Bezeichnung	Menge
0104010002	1	Bolt Ø16 l=100 mm f. HEFT	1
0104010003	2	PVC wear part	2
0104010004	3	Heel harrow field support left loose	1
1906010003	4	Cylinder liner TFZ3520	2
1905010003	5	Dowel pin ISO 8752 - 5 x 28 - A	1
1901060001	6	Truss-head screw DIN 603 - M8x70	4
1902010002	7	Hexagon nut DIN 982-M8	4
1906060001	8	Conical grease nipple DIN 71412 - A M8x1	1
1916010001	9	PVC plug d=48 mm	4
alternative			
0104020002	10	Heel harrow field beam right loose	

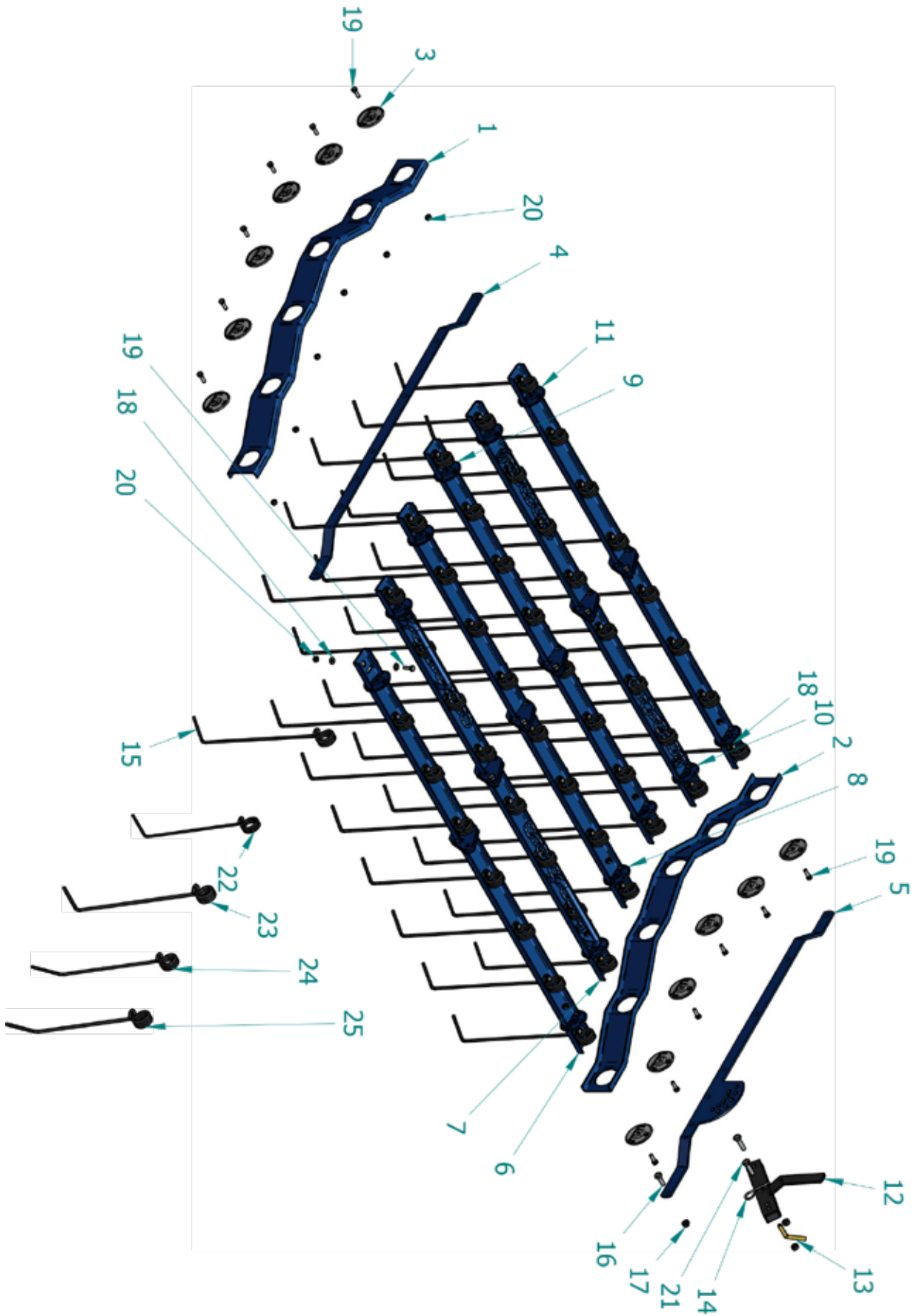

Thomas Hatzenbichler Agro-Technik GmbH

Fischering 2, A-9433 St. Andrä

Tel.: +43 4358 / 2287 - Fax: +43 4358 / 2208

e-mail: agrotechnik@hatzenbichler.com



Art. no.:	Pos. no.	Designation	Amount
0110010004	1	Side profile f. chopping harrow field left	1
0110010005	2	Side profile f. chopping harrow field right	1
0110010002	3	Washer f. chopping harrow field galvanized	12
0110010006	4	Flat iron f. adjustment at chopping harrow field	1
0110010003	5	Adjusting flat iron w. multi-hole for harrow field	1
0110010007	6	Tine profile 1 at hack harrow field 1.5m	1
0110010008	7	Tine profile 2 at hack harrow field 1.5m	1
0110010009	8	Tine profile 3 at hack harrow field 1.5m	1
0110010010	9	Tine profile 4 at hack harrow field 1.5m	1
0110010011	10	Tine profile 5 at hack harrow field 1.5m	1
0110010012	11	Tine profile 6 at hack harrow field 1.5m	1
0110010013	12	Adjustment lever f. chopping harrow field	1
1903030009	13	Locking pin Ø10 f. harrow field adjustment	1
1904020002	14	Spring cotter Ø4mm	1
1909030007	15	Chisel harrow tines 7mm	48
1901010025	16	Hexagon head screw DIN 933 M10x30	12
1902010005	17	Locking nut DIN 985 M10	14
1908010010	18	Washer DIN 134 M8	96
1901010032	19	Hexagon head screw DIN 933 M8x25	60
1902010002	20	Locking nut DIN 985 M8	60
1901010031	21	Hexagon head screw DIN 933 M10x40	2
alternative			
1909030006	22	Chisel harrow tines 6mm	1
1909030008	23	Chisel harrow tines 8mm	1
1909030009	24	Grassland tines 7mm	1
1909030010	25	Grassland tines 8mm	1

Thomas Hatzenbichler Agro-Technik GmbH

Fischering 2, A-9433 St. Andrä

Tel.: +43 4358 / 2287 - Fax: +43 4358 / 2208

e-mail: agrotechnik@hatzenbichler.com



Art.Nr.:	Pos.-Nr.	Bezeichnung	Menge
0109020002	1	Scraper 1,5m f. harrow	1
0109020001	2	Reinforcement ring f. stripe plate spring	2
0405060100	3	Holder f. C-rail on field beam - part 1	2
0405060101	4	Holder f. C-rail on field beam - part 2	2
1909030013	5	Stiffener f. stripe plate spring	2
1908010001	6	Washer M12 - DIN134	2
1901010015	7	Hexagon head screw DIN 931 M12x120	2
1901090004	8	Grub screw DIN 914 - M12x20 - A2	2
1909030012	9	Spring f. stripe plate - harrow	2
1901010025	10	Hexagon head screw DIN 933 M10x30	4
1902010005	11	Locking nut DIN 985 M10	4
alternative			
0405060002	12	Holder f. C-rail on field beam - set	2

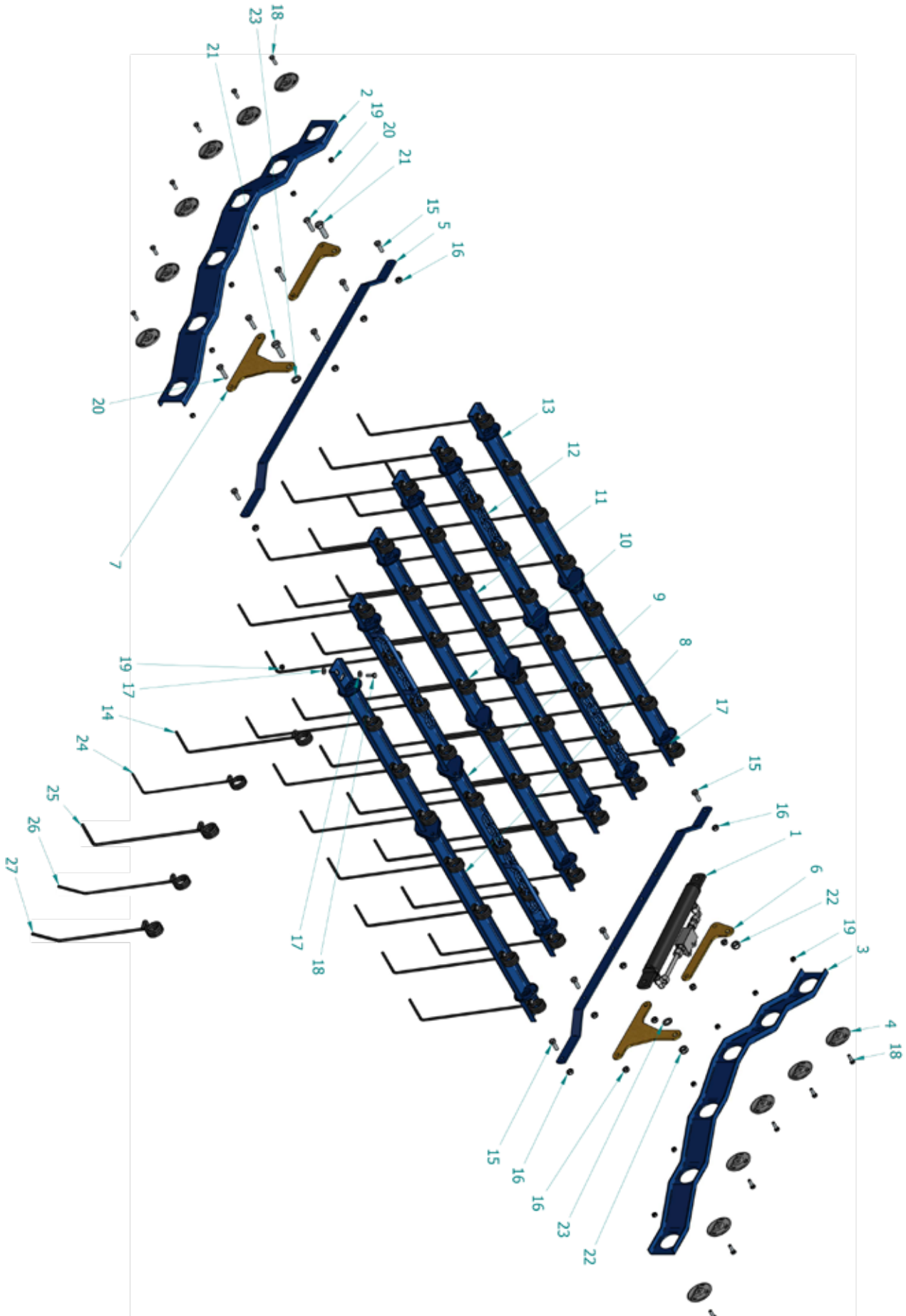

Thomas Hatzenbichler Agro-Technik GmbH

Fischering 2, A-9433 St. Andrä

Tel.: +43 4358 / 2287 - Fax: +43 4358 / 2208

e-mail: agrotechnik@hatzenbichler.com



Art. no.:	Pos. no.	Designation	Amount
1912010022	1	Hydraulic cylinder f. field adjustment incl. check valve	1
0110010004	2	Side profile f. chopping harrow field left	1
0110010005	3	Side profile f. chopping harrow field right	1
0110010002	4	Washer f. harrow field galvanized	12
0110010006	5	Flat iron f. adjustment at chopping harrow field	2
0199010331	6	Plate small f. hydraulic tine adjustment	2
0199010332	7	Plate large f. hydraulic tine adjustment	2
0110010007	8	Tine profile 1 at hack harrow field 1.5m	1
0110010008	9	Tine profile 2 at hack harrow field 1.5m	1
0110010009	10	Tine profile 3 at hack harrow field 1.5m	1
0110010010	11	Tine profile 4 at hack harrow field 1.5m	1
0110010011	12	Tine profile 5 at hack harrow field 1.5m	1
0110010012	13	Tine profile 6 at hack harrow field 1.5m	1
1909030007	14	Chisel harrow tines 7mm	48
1901010025	15	Hexagon head screw DIN 933 M10x30	8
1902010005	16	Locking nut DIN 985 M10	12
1908010010	17	M8 washer - DIN 134	96
1901010032	18	Hexagon head screw DIN 933 M8x25	60
1902010002	19	Locking nut M8 - DIN 985	60
1901010031	20	Hexagon head screw DIN 933 M10x40	4
1901010055	21	Hexagon head screw DIN 933 M14x45	2
1902010004	22	Locking nut M14 - DIN 985	2
1908010011	23	Washer M14 - DIN134	2
alternative			
1909030006	24	Chisel harrow tines 6mm	1
1909030008	25	Chisel harrow tines 8mm	1
1909030009	26	Grassland tines 7mm	1
1909030010	27	Grassland tines 8mm	1

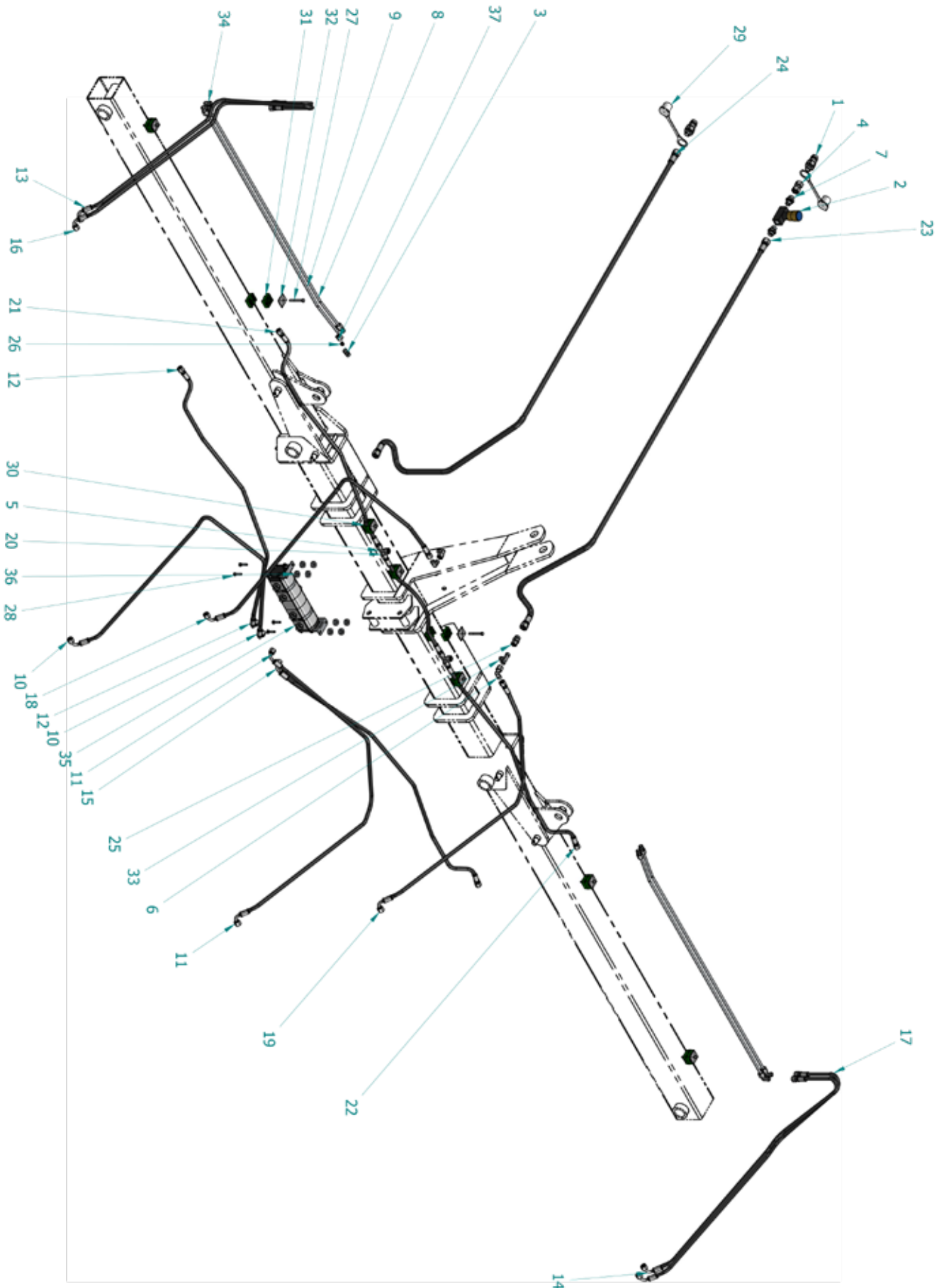

Thomas Hatzenbichler Agro-Technik GmbH

Fischering 2, A-9433 St. Andrä

Tel.: +43 4358 / 2287 - Fax: +43 4358 / 2208

e-mail: agrotechnik@hatzenbichler.com



Art.Nr.:	Pos.-Nr.	Bezeichnung	Menge
1912030001	1	12L Push Pull Plug	2
1912060005	2	12L_throttle valve	1
1912030026	3	8L Bolting straight	4
1912030017	4	Double nut 12L	1
1912030032	5	Adjustable T-fitting 8L	2
1912030033	6	adjustable elbow fitting 8L - 90°	2
1912030011	7	straight screw-in gland 3/8"x12L	2
1912140019	8	Hydraulic pipe Ø8 straight-bent l=1000mm	2
1912140019	9	Hydraulic pipe Ø8 straight-bent l=1000mm	2
1912020075	10	Hydraulic hose DN6 bent-bent l=1560mm	1
1912020075	11	Hydraulic hose DN6 bent-bent l=1560mm	1
1912020064	12	Hydraulic hose DN6 bent-straight l=1150mm	1
1912020064	13	Hydraulic hose DN6 bent-straight l=1150mm	1
1912020064	14	Hydraulic hose DN6 bent-straight l=1150mm	1
1912020064	15	Hydraulic hose DN6 bent-straight l=1150mm	1
1912020052	16	Hydraulic hose DN6 bent-straight l=1200mm	1
1912020052	17	Hydraulic hose DN6 bent-straight l=1200mm	1
1912020069	18	Hydraulic hose DN6 straight-bent l=1300mm	1
1912020069	19	Hydraulic hose DN6 straight-bent l=1300mm	1
1912020074	20	Hydraulic hose DN6 straight-straight l=400mm	1
1912020066	21	Hydraulic hose DN6 straight-straight l=900mm	1
1912020066	22	Hydraulic hose DN6 straight-straight l=900mm	1
1912020036	23	Hydraulic hose DN8 straight-straight l=1500mm	1
1912020036	24	Hydraulic hose DN8 straight-straight l=1500mm	1
1912030027	25	Reducer connector 8L-12L	1
1912030024	26	Cutting ring 8L	8
1901010090	27	Hexagon head screw DIN 931 M6x50	8
1901010094	28	Hexagon head screw DIN 933 M6x25	4
1912040002	29	Dust cap white	2
1912070018	30	Stauff clamp size 1 Ø12mm - double	8
1912070019	31	Stauff clamp size 1 Ø8mm - double	8
1912070014	32	Stauff clamp cover size 1	8
1912030029	33	T-fitting 8L	1
1912030028	34	Elbow fitting 8L	5
1912060021	35	Gear flow divider_4 times_bolted	1
0199010336	36	Gear quantity divider_distance washer s=8mm	8
1912030025	37	Union nut 8L	8

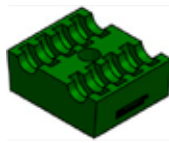

1912070019



1912070018



1912070014



1912030029

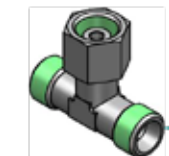

1912030032

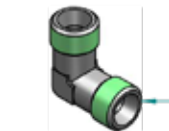

1912030028

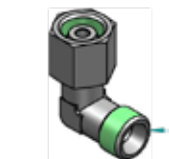

1912030033

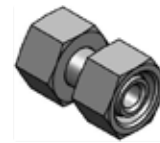

1912030017

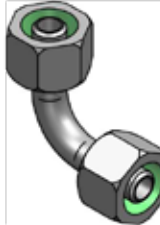

1912030003



1912030001



1912030027



1912030024



1912030025



1912030026



1912030011

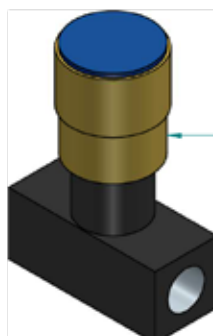

1912060005

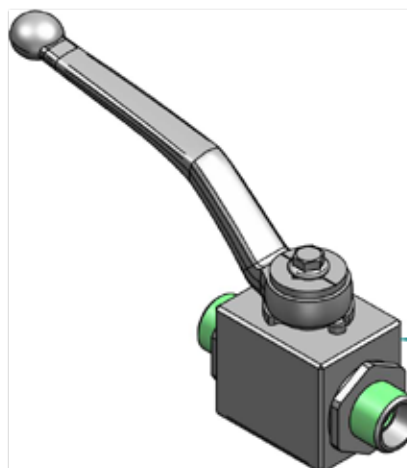

1912060001



www.hatzenbichler.com

All illustrations and specifications are approximate and non-binding.
We reserve the right to make technical or design changes.



Thomas Hatzenbichler Agro-Technik GmbH

Fischering 2, A-9433 St. Andrä

Tel.: +43 4358 / 2287 - Fax: +43 4358 / 2208

e-mail: agrotechnik@hatzenbichler.com